

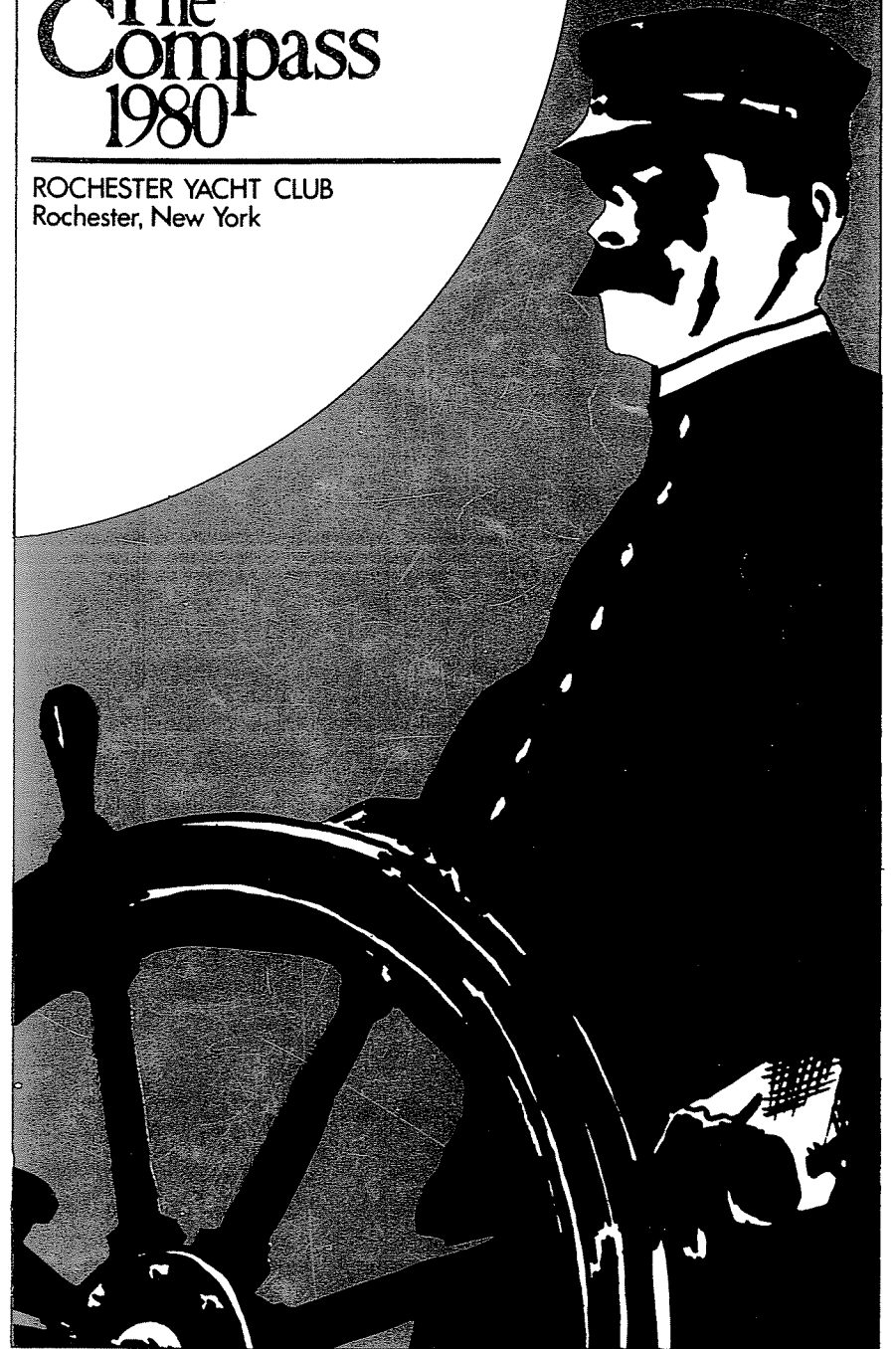

# The Compass 1980

---

ROCHESTER YACHT CLUB  
Rochester, New York



# The Compass

1980



Rochester Yacht Club  
5555 St. Paul Boulevard  
Rochester, New York 14617  
716-342-5511

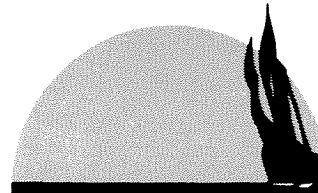

## TABLE OF CONTENTS

---

Rochester Yacht Club Officers and Directors . . . . .	4
Committees . . . . .	5-8
RYC Women's Association Officers . . . . .	9
Rochester Junior Yacht Club Officers . . . . .	11
Ladies' Racing Association Officers . . . . .	11
1979 Race Results	
Cruising Fleet . . . . .	12
Dragon Fleet . . . . .	18
J-24 Fleet . . . . .	20
Soling Fleet . . . . .	20
Ladies' Racing Association . . . . .	21
1979 U.S. Women's Championships . . . . .	22
IYRU Women's Worlds . . . . .	23
1979 Highlights . . . . .	24-31
1980 Calendar of Events . . . . .	32
1980 Racing Calendar . . . . .	33
Rochester Yacht Club Sailing Instructions . . . . .	40



## ROCHESTER YACHT CLUB 1980

### Officers

Commodore . . . . . William J. Stolze  
 Vice Commodore . . . . . Peter M. Woodams  
 Rear Commodore . . . . . Gordon R. Britton  
 Recording Secretary . . . . . Henry W. Williams, Jr.  
 Corresponding Secretary . . . . . Michael P. Riordon  
 Treasurer . . . . . Robert W. Warren  
 Past Commodore . . . . . Robert R. Rae  
 Fleet Captain (Sail) . . . . . Joseph P. Ingerson  
 Fleet Captain (Power) . . . . . Stephen Foti

### Directors

Henry A. Cashette	John M. Odenbach
John Karpf	Paul B. Schumacher
John W. Newell	Jack S. Allen

### Delegates to L.Y.R.A.

Henry W. Williams, Jr.	Dianne B. Ainslie
Arthur J. Bamann, Jr.	

### Governor to C.N.Y.Y.R.A.

Robert E. Castle



RYC Officers and Directors

Rear—Robert W. Warren, Robert R. Rae, John M. Odenbach, Paul B. Schumacher, John W. Newell, Jack S. Allen, John Karpf, Henry A. Cashette. Front—Michael Riordon, Peter M. Woodams, William J. Stolze, Gordon R. Britton, Henry W. Williams, Jr.

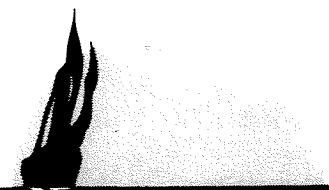

## COMMITTEES

### Administration

Peter M. Woodams, *Chairman*  
 Michael F. Walker                      Donald G. Murray

### Budget and Audit

George L. Guarino, *Chairman*  
 John Karpf                                      Robert W. Warren  
 Paul B. Schumacher                      Verner C. Kreuter  
 Charles G. Ross                              Donald G. Quick, Jr.  
 Peter M. Woodams

### Boating Safety

Dr. Donald Young, *Chairman*  
 E. Kelsey Scott                              Ervin F. Lyke  
 Marjorie Robfogel                              George F. Garfield  
 Bruce H. McKeon

### Club Cruise

Bruce H. McKeon, *Chairman*  
 Douglass L. Blanding                      Kate Karshick  
 Paul Haas, Jr.                                      Stephen Foti

### Construction

John M. Odenbach, *Chairman*

### Entertainment

Kenneth and Nicole Doolittle, *Chairmen*  
 Robert and Joyce Gugler  
 Jerry and Gail Lewis  
 Douglass and Rosemary Blanding  
 Philip and Joanne Cichanowicz  
 Thomas and Mary Rowe  
 John Wilson  
 John and Suzanne Titus  
 John and Leslie Clapper  
 Harold and Polly Lowry



## COMMITTEES

### House and Pool

Paul B. Schumacher, *Chairman*  
 Robert M. Dunlap                      Ingalls S. Bradley  
 William R. Kaiser                      Peter B. Heinrich  
 James J. Barnash                      Carol Fenton  
 Gerald Caschette                      Richard J. Handler  
 Maryann Haas                          Jay Wm. Gilbert  
 Cornelia Cowles                      Shirley Dunlap  
 Fern Schumacher, *Chairman, Pool Sub-Comm.*

### Sailing Instruction

Stanley C. Wright, *Chairman*  
 Wiles E. Converse, *Junior Instruction*  
 Robert D. Fields, *420, Laser Instruction*  
 Martin A. Karch, *Junior Racing*  
 Joseph A. and Antoinette McGrain, *Adult Instruction*  
 John Karpf, *Consultant*  
 Michael C. Dwyer, *Property, Sail*  
 John Thomson, *Property, Sail*  
 Joel A. Grosshans, *Property, Power*  
 Joyce Gugler, *Finance, Awards*  
 Suzanne Fischer, *Ladies Liaison*  
 Robert J. MacDonald, *Director*

### Junior Yacht Club

Martin A. and Sheryl Karch, *Advisors*

### Log and Compass

Patricia Polidor, *Chairman*  
 Suzanne Fischer                      Raymond D. DelMonte  
 Jerome Lewis                          Julia Bolton

### Long-Range Planning

Frank R. Shumway, Jr., *Chairman*  
 Ervin F. Lyke                              Jonathan C. Heinrich  
 William B. Burks                      Wilmot V. Castle, Jr.

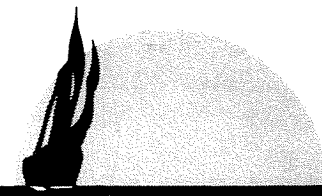

## COMMITTEES

### Membership

Gordon R. Britton, *Chairman*  
 Richard M. Blair                      Nancy Broderson  
 Henry A. Cashette                      Tom Hiatt  
 Arthur W. Schuster, Jr.                      John D. McGrath  
 Jack S. Allen

### One-Design

Glenn F. Litchfield, *Chairman*  
 Bruce M. Cameron                      Orion E. Schupp III  
 Charles G. Ross                          Robert W. Castle  
 Frank R. Shumway, Jr.                      Victoria Gilbert  
 James E. Kraft                              Stanley C. Wright

### Property

John Karpf, *Chairman*  
 Jack S. Allen                              John C. Bereza  
 Douglas C. Burkhardt                      Henry A. Cashette  
 Robert H. Fella                              John B. Floyd  
 Joseph P. Ingerson                      Frederick Karshick  
 Edward Mayer                              John J. Ozols

### Protest

Arthur J. Bamann, Jr., *Chairman*  
 Wilmot V. Castle, Jr.                      Denis Doyle  
 Richard J. Handler                      H. Robb Holt  
 Frank R. Shumway, Jr.                      Charles G. Ross  
 Howard M. Low                              John M. Odenbach, Jr.  
 Scott Mitchell                              Howard Rekers  
 Edward T. Polidor                              Helen Ingerson

### Publicity

Andrea D. Lyke, *Chairman*  
 Dianne B. Ainslie                      William T. Stolze

## COMMITTEES

### Sailing and Race Management

Charles G. Ross, *Chairman*  
 John W. Newell  
 James E. Kraft  
 Glenn F. Litchfield  
 Tom Smith  
 William D. Evans  
 Keith Burhans  
 Douglass L. Blanding  
 Martin Muszak

### Tennis

Cheryl Walsh, *Chairman*  
 Joseph and Noreen Incavo  
 Mary Ann Taranto  
 Gretchen Heinrich  
 Bradley and Jane Jones  
 James and Gail Nealon

### Trophy and Historical

Andrea Walker, *Chairman*  
 Paul B. Schumacher  
 Walter R. Roberts  
 Joseph P. Ingerson

### Regatta

Dianne B. Ainslie, *Chairman*  
 Ervin F. Lyke  
 Frederick A. Bauman  
 Fern Schumacher  
 Marjorie Robfogel  
 Frank R. Shumway, Jr.  
 Jane Lavery-Jones  
 Andrea D. Lyke

### Measurers

John F. Ernst  
 H. Robb Holt

### Cruising Fleet Captain

Henry W. Williams, Jr.

### Club Manager

William J. Kreher

### Yard Master

Edwin J. Gallavin

### House Steward

Ellsworth Storey

### Office Manager

Rosemary Millhofer

### Head Waitress

Monica Montrois

## RYC WOMEN'S ASSOCIATION



Front— Maryann Haas, Ann Hiatt, Sue Connard. Middle— Carol Fenton, Geri Foti. Rear— Doris Burks.

### Officers

*President* . . . . . Carol Fenton  
*First Vice President* . . . . . Geri Foti  
*Second Vice President* . . . . . Ellen Taylor  
*Program Co-Chairmen* . . . . . Geri Foti, Ellen Taylor  
*Treasurer* . . . . . Doris Burks  
*Recording Secretary* . . . . . Sue Connard  
*Corresponding Secretary* . . . . . Ann Hiatt  
*Regatta Chairman* . . . . . Shirley Dunlap  
*Past President* . . . . . Maryann Haas



## ROCHESTER JUNIOR YACHT CLUB



Front— Beth Sertl, Karen Wright, Skip Shumway, Renée Bianco, Alicia Incavo. Rear— Sheryl Karch, Neil Rohrer, Peter Woodams, Jr., Martin Karch.

### Officers

Commodore . . . . .	Skip Shumway
Vice Commodore . . . . .	Renée Bianco
Treasurer . . . . .	Neil Rohrer
Secretary . . . . .	Karen Wright
Corresponding Secretary . . . . .	Cindy Brown
House Chairman . . . . .	Beth Sertl
Social Chairman . . . . .	Alicia Incavo
Fleet Captain . . . . .	Peter Woodams, Jr.
Past Commodore . . . . .	Kevin Moran
Advisors . . . . .	Martin and Sheryl Karch

## LADIES' RACING ASSOCIATION



Vicky Gilbert, Sue Fischer, Joan Ellison, Barbara Towner, Joan Fella.

### Officers

Chairman . . . . .	Vicky Gilbert
Vice Chairman . . . . .	Sue Fischer
Secretary . . . . .	Joan Ellison
Treasurer . . . . .	Toni McGrain
Past Chairman . . . . .	Joan Fella
Steering Committee . . . . .	Barbara Towner

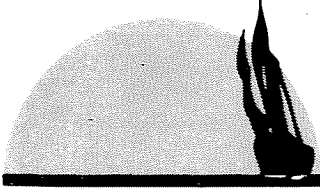

## 1979 RACE RESULTS

### CRUISING FLEET

The Cruising Fleet consisted of approximately 40 boats during the 1979 season, and was almost equally split between IOR and PHRF in most of the regular series races.

#### Memorial Day Race

##### IOR I

- 1st Susan B. Anthony
- 2nd Mallard
- 3rd Ping

##### IOR II

- 1st No End
- 2nd Wild Card
- 3rd Eclipse

##### Overall

- 1st No End
- 2nd Susan B. Anthony
- 3rd Mallard

##### PHRF I

- 1st Sandpiper
- 2nd Cherokee
- 3rd Newsboy

##### PHRF II

- 1st Wisp
- 2nd Vitesse
- 3rd Lea Sea

##### Overall

- 1st Sandpiper
- 2nd Cherokee
- 3rd Newsboy

#### Spring Wednesday Night Series

##### IOR I

- 1st Rampage
- 2nd Audacity
- 3rd Susan B. Anthony

##### IOR II

- 1st Wild Card
- 2nd Eclipse
- 3rd Umi Taka

##### Overall

- 1st Rampage
- 2nd Audacity
- 3rd Susan B. Anthony

##### PHRF I

- 1st Latent Image
- 2nd White Pepper
- 3rd Bete Noire

##### PHRF II

- 1st Kindo
- 2nd Vitesse
- 3rd Pegasus

##### Overall

- 1st Latent Image
- 2nd White Pepper
- 3rd Bete Noire

#### Spring Sunday Series

##### IOR I

- 1st Rampage
- 2nd Susan B. Anthony
- 3rd Bamco

##### IOR II

- 1st No End
- 2nd Wild Card
- 3rd Eclipse

##### Overall

- 1st Rampage
- 2nd Susan B. Anthony
- 3rd Bamco

##### PHRF I

- 1st Persephone
- 2nd White Pepper
- 3rd Cherokee

##### PHRF II

- 1st Ragamuffin
- 2nd Wisp
- 3rd Chubasco

##### Overall

- 1st Persephone
- 2nd Cherokee
- 3rd White Pepper

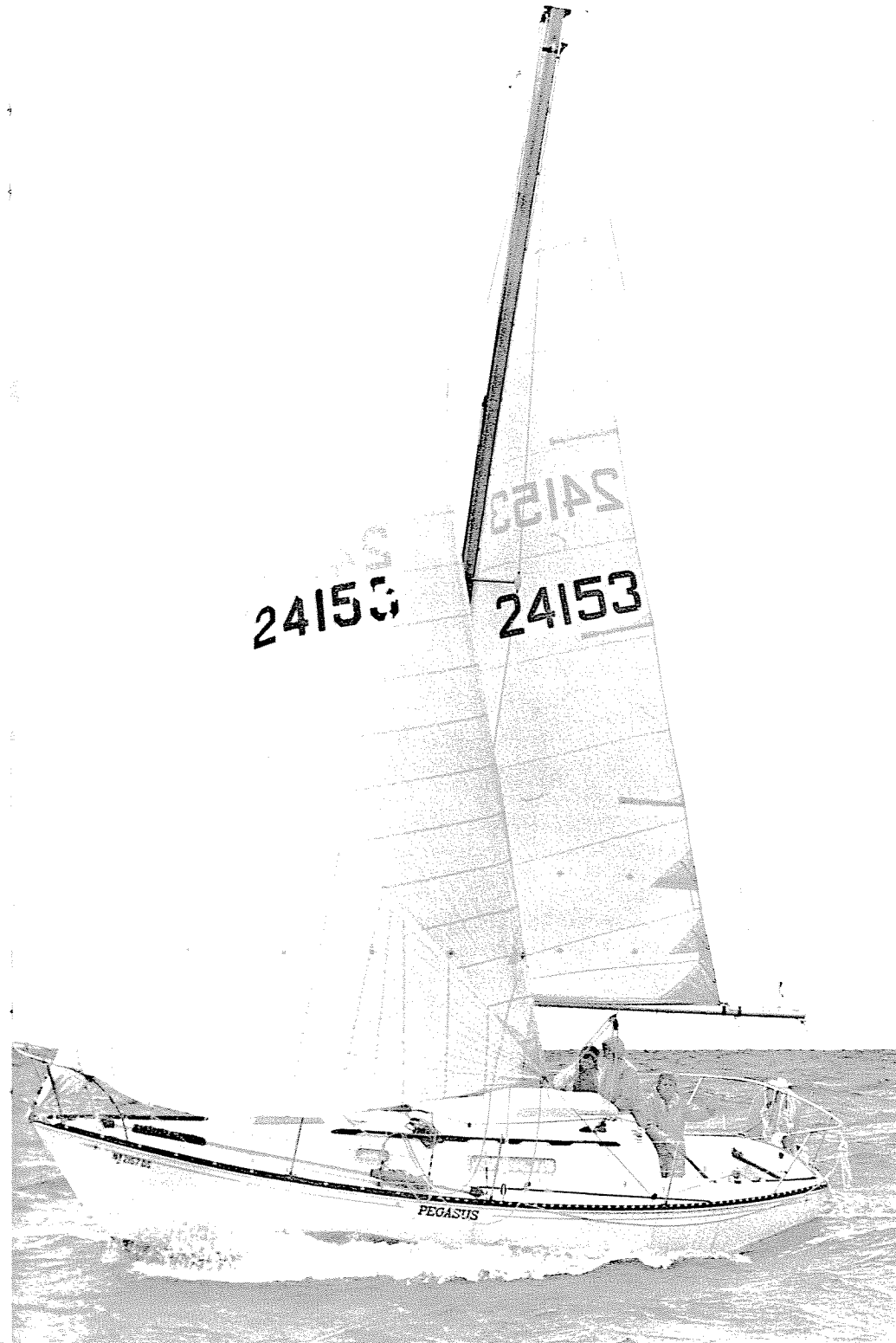



## 1979 RACE RESULTS



Rampage, John Odenbach, skipper, was awarded the Madge Cup at RYC's Cups 'n Flags for the best overall racing performance during the 1979 season.

### Presqu'île Race

- 1st Eclipse
- 2nd Wild Card
- 3rd Sawbuck

### Sodus Race

- Tie {
- 1st Rampage
  - 1st Sideband
  - 3rd Ping

### IOR II

- 1st Wild Card
- 2nd Alarm
- 3rd UmiTaka

### IOR Overall

- Tie {
- 1st Rampage
  - 1st Sideband
  - 3rd Ping

### PHRF Overall

- Tie {
- 1st Iroquois
  - 2nd Zest
  - 2nd Sawbuck

### Summer Series

#### PHRF I

- Tie {
- 1st Rampage
  - 1st Latent Image
  - 3rd Sawbuck

#### PHRF II

- 1st Cherokee
- 2nd No End
- 3rd Sandpiper

#### PHRF III

- 1st Kindo
- 2nd Vitesse
- 3rd Ragamuffin

#### Overall

- 1st Rampage
- 2nd Latent Image
- 3rd Cherokee

## 1979 RACE RESULTS

### Fall Sunday Series

#### IOR I

- 1st Rampage
- 2nd Audacity
- 3rd Susan B. Anthony

#### IOR II

- 1st Wild Card
- 2nd Eclipse
- 3rd No End

#### IOR Overall

- 1st Rampage
- 2nd Audacity
- 3rd Susan B. Anthony

#### PHRF I

- 1st White Pepper
- 2nd Latent Image
- 3rd Panache

#### PHRF II

- 1st Cherokee
- 2nd Kemah
- 3rd Sandpiper

#### PHRF III

- 1st Vitesse
- 2nd Ragamuffin
- 3rd Pegasus

#### PHRF Overall

- 1st Latent Image
- 2nd White Pepper
- 3rd Panache

### Fall Wednesday Night Series

#### IOR I

- 1st Rampage
- 2nd Susan B. Anthony
- 3rd Bamco

#### IOR II

- 1st Eclipse
- 2nd No End
- 3rd Wild Card

#### IOR Overall

- 1st Rampage
- 2nd Susan B. Anthony
- 3rd Bamco

#### PHRF I

- 1st Latent Image
- 2nd White Pepper
- 3rd Panache

#### PHRF II

- 1st Kemah
- 2nd Sizzling Hot
- 3rd Cherokee

#### PHRF III

- 1st Kindo
- 2nd Charisma
- 3rd Vitesse

#### PHRF Overall

- 1st White Pepper
- 2nd Latent Image
- 3rd Kemah

RYC Cruising Fleet boats placed extremely well in off-the-lake races during the 1979 season. In the Lake Erie Race, Tarry Polidor's **Wild Card** placed first in IOR Division II. Jim Robfogel's **Ping** finished fourth in the same Division. Henry Williams' **Susan B. Anthony** finished seventh in IOR Division I. In the Port Huron to Mackinac Race, **Ping** placed third in her Division.

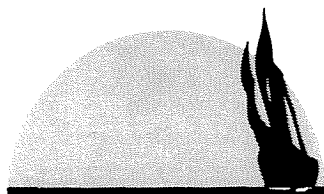

## 1979 RACE RESULTS

Again, RYC represented itself well in the Lake Yacht Racing Association Racing Series. The results were impressive:

### Freeman Cup Race

#### IOR I

- 1st Dynamo (RCYC)
- 2nd Impetus (RCYC)
- 3rd Rampage

#### IOR II

- 1st Red Jacket (RCYC)
- 2nd Ping
- 3rd Bamco
- 6th Foxfire

#### IOR IV

- 1st No End
- 2nd Wave Train
- 3rd Umi Taka
- 4th Wild Card
- 6th Eclipse

#### PHRF I

- 1st Latent Image
- 2nd Avis
- 3rd Kemah

#### 8 Meters

- 5th Iroquois

### LYRA Course Racing

#### IOR I

- 1st Impetus (RCYC)
- 2nd Blythe (RCYC)
- Tie { 3rd Susan B. Anthony
- 3rd Dynamo (RCYC)

#### IOR II

- 1st Spirit (NOLSC)
- 2nd Red Jacket (RCYC)
- 3rd Cannonball (YYC)
- 4th Ping

#### IOR IV

- 1st Wave Train
- 2nd Wild Card
- 3rd Eclipse
- 4th No End

#### PHRF I

- 1st Panache
  - 2nd Latent Image
  - 3rd Impulse (RCYC)
  - 4th Sawbuck
- 8 Meters**
- 1st Iroquois
  - 2nd Norseman III (RCYC)
  - Tie { 3rd Quest (RCYC)
  - 3rd Venture II (RCYC)

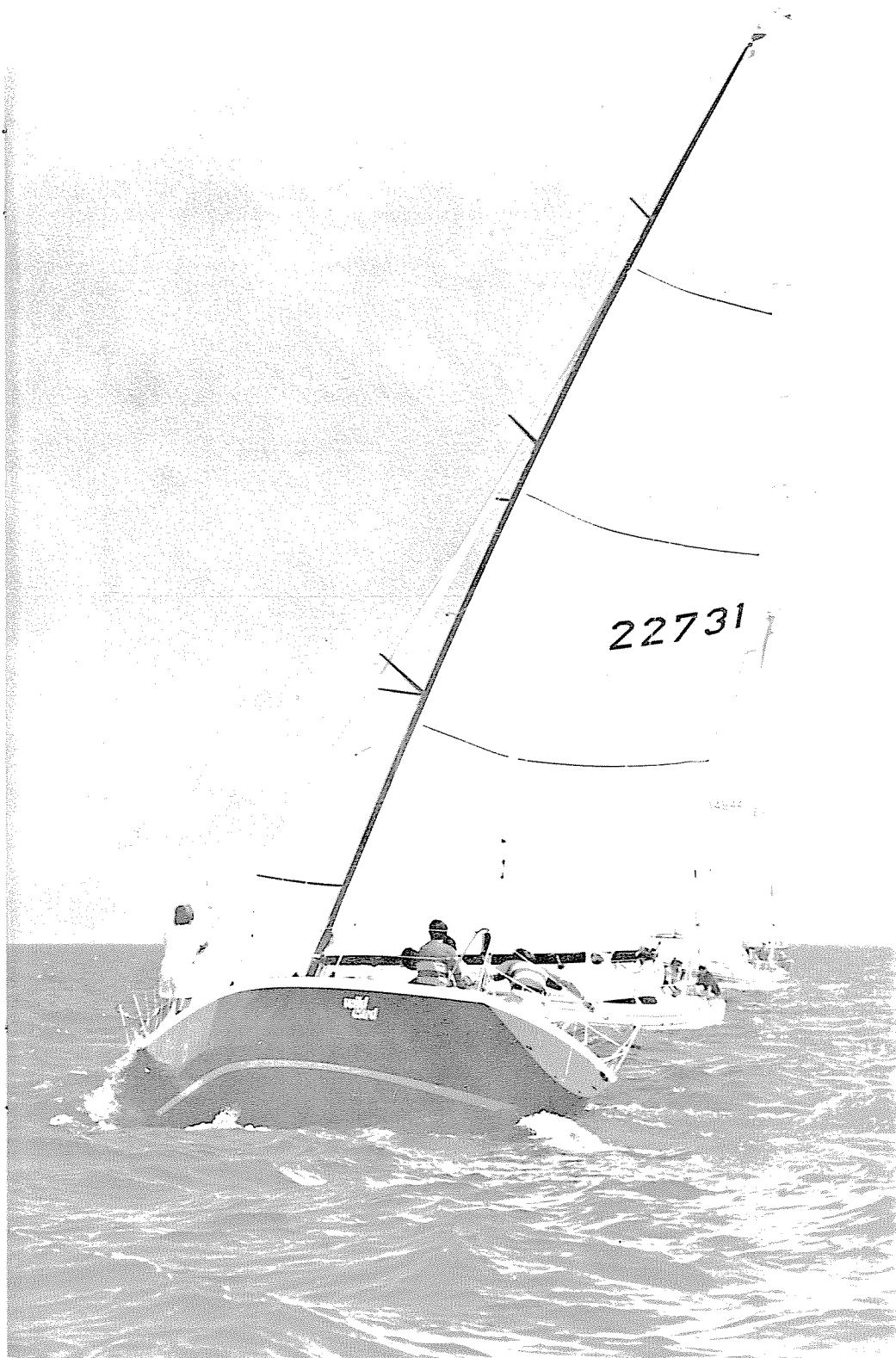

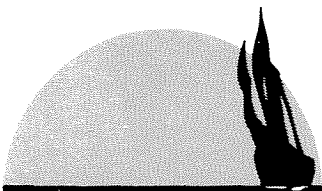

## 1979 RACE RESULTS

### Centennial Race

#### IOR I

- 1st Amazing Grace (PCYC)
- 2nd Impetus (RCYC)
- 3rd Dynamo (RCYC)
- 4th Rampage
- 5th Ping

#### IOR II

- 1st Shamrock (Ithaca)
- 2nd Wild Card
- 3rd Eclipse
- 4th No End
- 5th Wave Train

#### PHRF

- 1st Advent
- 2nd Bluebird (BYC)
- 3rd Latent Image

### Lake Ontario International

#### IOR I

- 1st Rampage
- 2nd Impetus (RCYC)
- 3rd Susan B. Anthony

#### IOR II

- 1st Nirie V (YYC)
- 2nd Big Bird (NOLSC)
- 3rd Ping
- 4th Mallard
- 5th Sawbuck

#### IOR III

- 1st Silver Fox (RCYC)
- 2nd Boomerang (Bayview YC)
- 3rd Wave Train
- 4th Eclipse
- 5th Panache
- 6th Wild Card

America regained the Team Trophy, as its sailors finished better overall than the Canadian sailors in the LOI.

### DRAGON FLEET

During the 1979 racing season, O.E. Schupp finished with the best overall record. He also did quite well in outside competition, placing 1st after the first 3 races of the North Americans, 3rd in the Great Lakes Championship, and 3rd place in both the Founder's Trophy and George Trophy competitions.

#### Spring Series

- 1st O.E. Schupp III
- 2nd Phil Enriquez
- 3rd Glenn Webster

#### Summer Series

- 1st Howard Low
- 2nd Phil Enriquez
- 3rd D. Frickey (R.J.Y.C.)

#### Mayor's Cup

- 1st O.E. Schupp III
- 2nd Howard Low
- 3rd T. Lajos (Youngstown Y.C.)

#### Fall Series

- 1st O.E. Schupp III
- 2nd Howard Low
- 3rd Richard Klingbiel

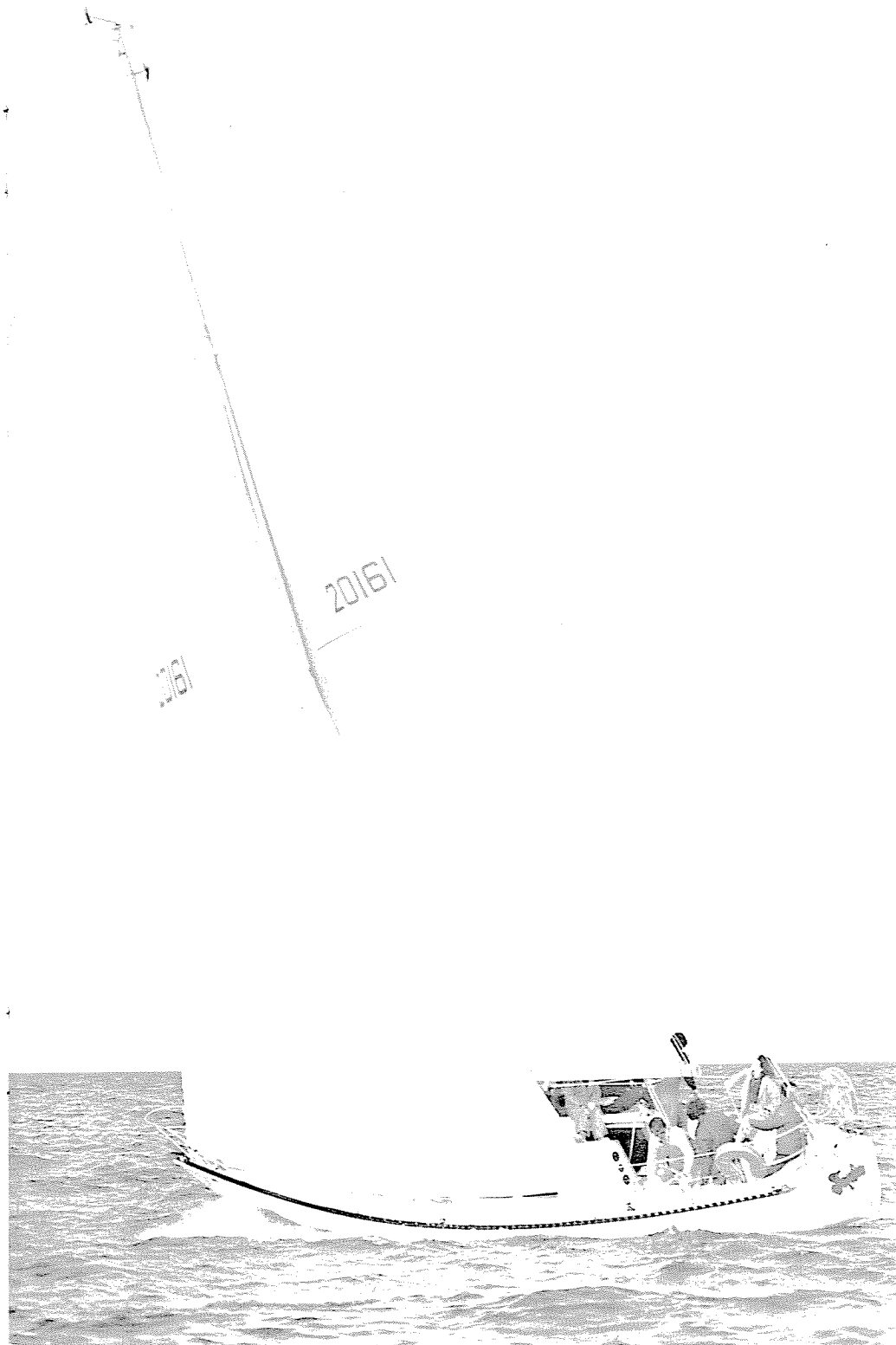



## 1979 RACE RESULTS

### J-24 Fleet

1979 was the first racing season for the J-24's as a one-design fleet, and they enjoyed very active and enthusiastic competition. They started the Spring Series with only 5 boats and added one more during the season. They have continued to grow and will have at least 12 boats competing at the start of the 1980 season. The results were as follows:

#### Spring Saturday Series

- Tie { 1st Keith Burhams  
1st Jim Kraft  
2nd Greg Doyle  
3rd Mike Nahmias

#### Fall Saturday Series

- 1st Keith Burhams  
2nd Verne Krueter  
3rd Mike Nahmias

#### Overall Saturday Series

Keith Burhams

#### Spring Sunday Series

- 1st Jim Kraft  
2nd Charlie Ross  
3rd Mike Nahmias

#### Fall Sunday Series

- 1st Irv Feldman  
2nd Verne Krueter  
3rd Jim Kraft

#### Overall Sunday Series

Irv Feldman

#### Overall for Season

Jim Kraft

### Soling Fleet

The Soling Fleet continued to be strong and active, both in their regular Club series, and in their participation at other events. Denis Doyle and John Odenbach, Jr. vied for the top spots at two outside competitions — Denis placing 1st in the B Division at C.O.R.K., John 3rd; John placing 2nd in Youngstown, Denis 3rd. The '79 results of their Club racing were:

#### Season Championship (Overall)

- 1st Denis Doyle  
2nd John Odenbach, Jr.  
3rd Jerry Castle

#### Season Championship (Red Div.)

- 1st Alan Pundt  
2nd Dave Rutherford  
3rd Rick Eberhardt

#### Sat. Season Championship (Overall)

- 1st Denis Doyle  
2nd Bruce Cameron  
3rd Alan Pundt

#### Sat. Season Championship (Red Div.)

- 1st Alan Pundt  
2nd Dave Rutherford  
3rd Herb LePage

#### Sun. Season Championship (Overall)

- 1st Denis Doyle  
2nd John Odenbach, Jr.  
3rd Jerry Castle

#### Sun. Season Championship (Red Div.)

- 1st Alan Pundt  
2nd Rick Eberhardt  
3rd Dave Rutherford

### Ladies' Racing Association

This past year the Ladies' Racing Association consisted of six 420's and raced one night each week during June and August. The results:

#### June Series

- 1st Lynne Low, *Skipper*  
Joan Fella, *Crew*  
2nd Vicky Gilbert, *Skipper*  
Joan Ellison, *Crew*  
3rd Barbara Towner, *Skipper*  
Carol Fenton, *Crew*

#### August Series

- 1st Lynne Low, *Skipper*  
Ellen Taylor, *Crew*  
2nd Barbara Towner, *Skipper*  
Carol Fenton, *Crew*  
3rd Jane Lavery-Jones, *Skipper*  
Tony McGrain, *Crew*



## 1979 U.S. WOMEN'S CHAMPIONSHIPS

The most exciting event during the 1979 sailing season began when RYC hosted the U.S. Women's Doublehanded and Singlehanded Championships and the International Yacht Racing Union's World Women's Sailing Championships.

Fifty women participated in the Women's Nationals held here in July. They came from all over the East and as far as California to

compete. Several RYC women placed well in the overall standings: In the Singlehanded event Carolyn Holahan finished 21st; in the Doublehanded event the best RYC finishers among 20 boats were: Nancy Kaiser and Elizabeth Britton, 9th; Helen Ingerson and Jennie Brown, 10th. The top three finishers in each category returned to compete in the Women's Worlds in September.



Helen Ingerson (right) congratulating USYRU Laser winner Betsy Gelenitus.



Jo Ingerson hoisting the competitors' yacht club burgees, marking the start of the Worlds.

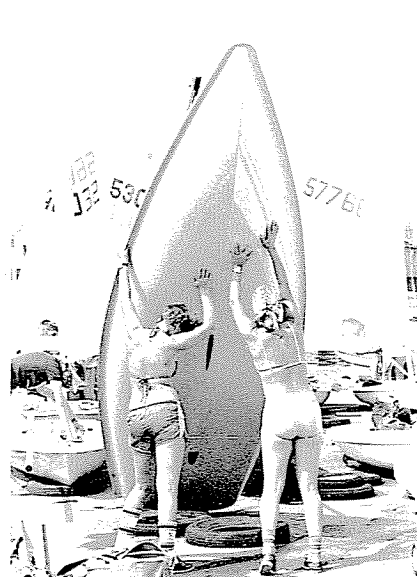

Bottoms Up!

## IYRU WOMEN'S WORLDS

Ninety women from 17 countries competed in the Worlds, allowing 3 entries per country in both the singlehanded and doublehanded classes and represented the highest level of racing in which women race separately from men. During the 7 days of racing, 6 races were run on Olympic courses, and the winds varied from day to day from under 5 knots to over 30! It was a tremendous week of racing, in which 2 Swedish women fought a

final-race duel for the Laser title; and the defending 420 champions from England won the Doublehanded championship, with the American team of Nell Taylor and Charlotte Lewis second.

The regatta was a huge success and helped determine the significance of separate women's events throughout the world, and what the future of women in sailing might be.



Members of the International Jury for the World Championships: Top—Ken Ryan (Ireland); Middle—Carlo Rolandi (Italy), Robert Sloane (Mexico), Beecher Moore (England); Front—Frank R. Shumway Jr. (USA), Gavia Wilkinson-Cox (England-Secretary).

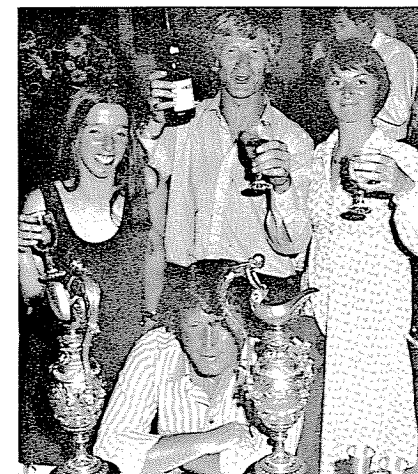

Proud IYRU Doublehanded Champions Cathy Foster (left) and Wendy Hilder (right) with coaches.



Sweden's Marit Soderstrom, World Singlehanded Champion.

Memorial Day ... the start of a new boating season.



RJYC Commodore Kevin Moran firing the cannon at Morning Colors on Memorial Day.

Rochester Yacht Club was privileged to host several other regattas this year.



The Van Voorhis family enjoying the Memorial Day Parade on board their tug *The Shad*.

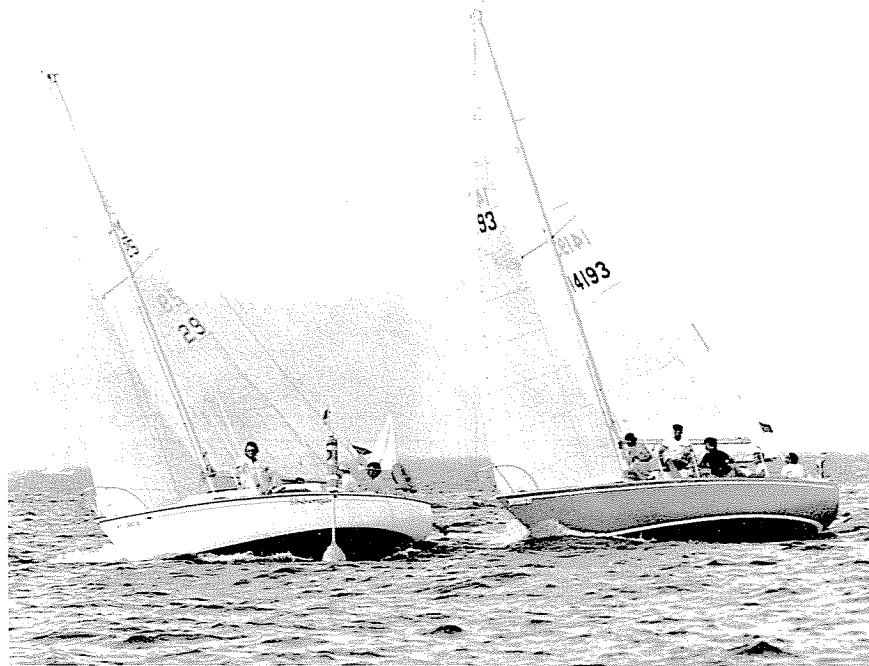

Gerry Wright's *Chubasco* finished 3rd in the Fifth Annual Sabre Regatta held at RYC in August. Nine boats from area yacht clubs participated in the event and completed three Olympic Circle course races.



The Basin swelled as some 130 boats assembled to begin the Freeman Cup Race in early August. Several weeks later many of the same boats returned in order to finish the longer distance Lake Ontario International.

The Soling Fleet's annual Firecracker Regatta was held during the July 4th weekend. With 31 entrants from the Northeastern U.S. and Canada participating, the Firecracker has come to be considered by some as an Olympic qualifying event. Five races were run during the three days of competition, John Odenbach, Jr. finishing 2nd overall.



From the left— Margie Robfogel, Skipper; Anita Fischer, Dianne Ainslie, Maureen Williams.

Two teams competed in the RYC Adams Cup Eliminations. Helen Ingerson, with her crew of Maureen Williams, Laramie Brown, and Anita Fischer, went on to represent the LYRA in the Area E Semi-Finals in Chicago.



RYC's Adams Cup Eliminations winners Helen Ingerson, Skipper; Carolyn Holahan, Laramie Brown, Lynne Low.



RYC was privileged to represent the Yacht Racing Union of the Greats Lakes at the Congressional Cup competition in Long Beach, California, in March. Shown on board the Cal 40 used in the competition are: Front— Dick Eberhardt, John Odenbach, Jr., Tim Nally; Rear— Fritz Odenbach, Eric Schwenk, Gardner Odenbach, Woody Hawks.



The J-24's held an area regatta late in June. It was the first regatta the Club has held for the Class and we are pleased that the J-24's have become an active one-design fleet. Shown here is Jim Kraft's *Magic Carpet*.

The North American Half Ton Regatta was held in August and completed an exciting series despite only three boats competing. A medium distance race and three match races were held, with the Lake Ontario International fulfilling the long-distance requirement. **Boomerang**, from Bayview Yacht Club in Detroit, emerged as the winner. **Wild Card** and **Eclipse**, both RYC half-tons, finished second and third respectively.



The Winners: "Where do you put the gas?" Putt-Putts: Top — Henry Cashette, Bob Warren, Joel Grosshans, Ed Carson, John Ernst. Middle — Chuck Lisson, Henry O'Neill, John Odenbach (owner), Ken Morrell, Don Potter. Bottom — Steve Foti, Doug Bennet, Walt Chappelle.

One of the more social races of the season was the annual Puff-Putt Race. The Puffs (Sailors) battled the Putt-Putts (Power Boaters) in two similarly sized sailboats, **Rampage** and **Sideband**. The

owners of each boat graciously relinquished their skippering capacities, but remained on board. After much good-natured protest on whether certain rules had been infringed upon, the race ended in a tie.

The Winners: "We supply our own hot air!" Puffs: Top— Cliff Sertl, Nick Desiderio, Bob Fields, Scott Mitchell, Howie Rekers, Jack Allen. Bottom— Jo Ingerson, Bill Stolze (owner), Bruce McKeon, Frank Shumway, Pete Woodams, Helen Ingerson.

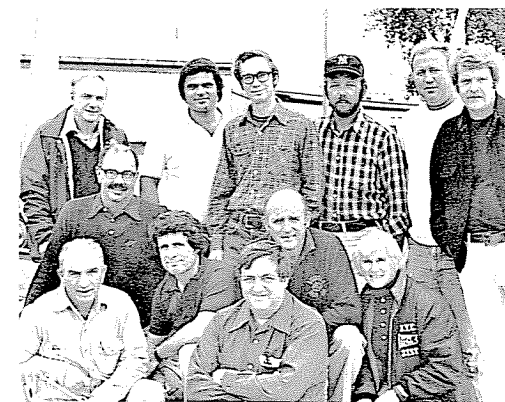

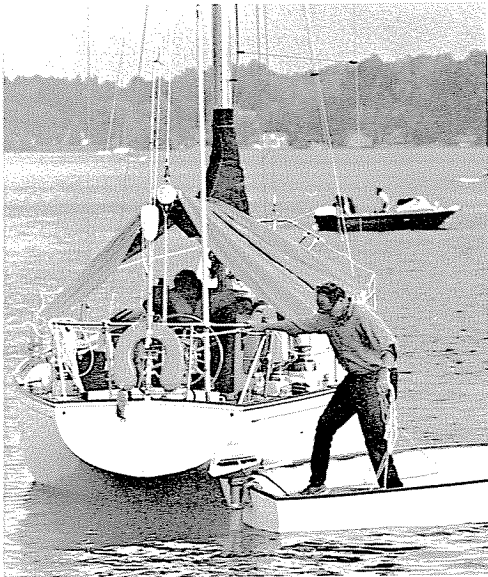

Good luck, Don!

**SUMMER CRUISE**

In late June over 40 boats gathered their docking lines, left their slips, and began the annual Club Cruise. The schedule this year took them first to a rendezvous at Fairhaven State Park. Some boats then drifted away to seek their favorite island or cove for the remainder of the Cruise. But many stayed together throughout and followed the itinerary that routed them to the popular Thousand Islands Club, through the Canadian Islands, to Kingston, and home.

The serenity of Camelot Island.



As a symbol to mark the end of each sailing season, RYC boats venture up the Genesee River to the Veterans Memorial Bridge to anchor and raft together for an afternoon of comradery.

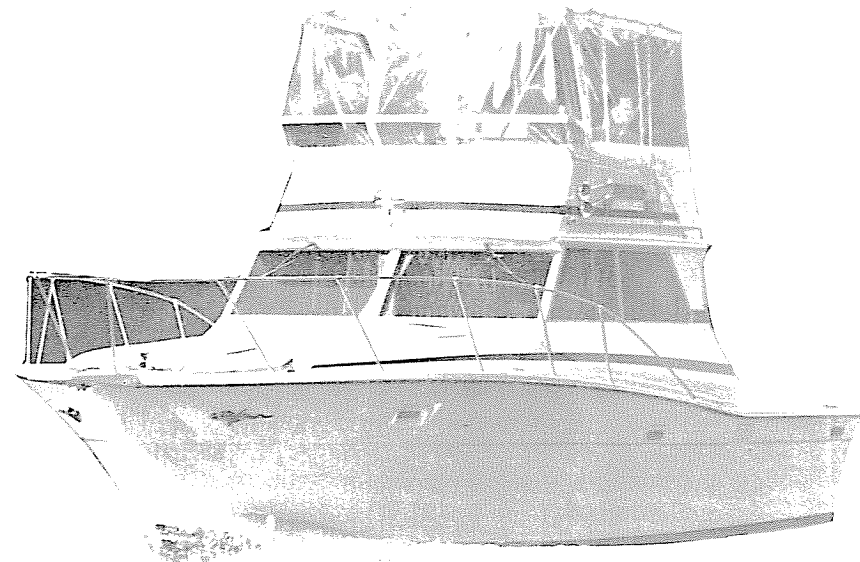





RYC members got together to make repairs in the Clubhouse during the regular Club closing in January. Installing the acoustical tiles are Jeff Hawley, Bob Rae, Pete Tierney, Paul Schumacher, Jack Riester, Hal Lowry, George Garfield, and Joe McGrain.

Wallpapering the Ladies' Lounge (below) are Toni McGrain, Joan Ellison, Geri Foti, Carol Fenton, and Ann Hiatt.



Throughout the year the Women's Association organized several children's parties. Halloween was a delightful blending of goblins and beauties; at Christmas time Santa arrived by boat; and at Easter the children were delighted with a clown's magic tricks.



There were four tennis tournaments held during the 1979 season: Mixed Doubles, Men's Singles, Ladies' Invitational, and Mixed-up Doubles.

Shown here are the Mixed Doubles runners-up Woody and Michelle Hawks with the winners Barbara and Doug Pinkerton.

Aaah...



Goodbye!!

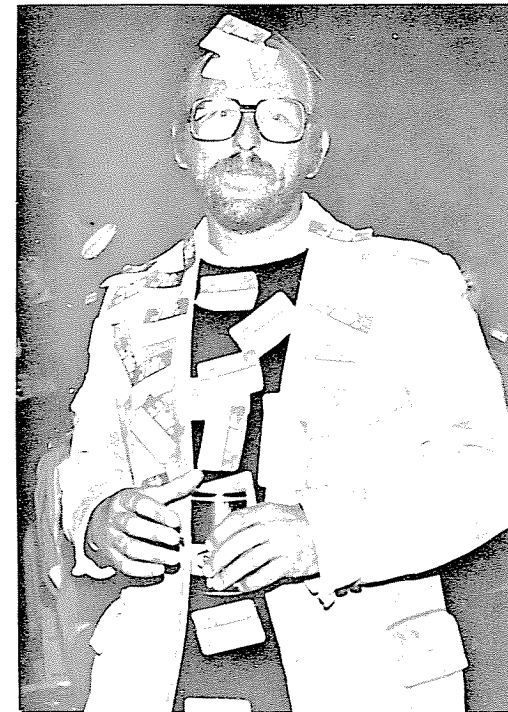

## 1980 CALENDAR OF EVENTS

### May

- 2 Start of Mixed Doubles Tennis Tournament
- 14 Women's Association Evening Program
- 17 Commodore's Ball
- 24 Rochester Junior Yacht Club Commodore's Ball
- 26 Morning Colors  
Afternoon Fleet Review and Commodore's Reception
- 28 Start of Adult Sailing Instruction, Level I
- 29 Start of Ladies' Invitational Tennis Tournament

### June

- 7 New Members' Party
- 11 Start of Adult Sailing Instruction, Level II
- 18 Women's Association Brunch, Shadow Lake Club

### July

- 7 Start of 420/Laser Race Clinic
- 14 Start of Junior Sailing Instruction, Levels I and III
- 18 Start of Eighty and Over, After Eight Tennis Tournament
- 28 Start of Junior Sailing Instruction, Levels II and III

### August

- 29 Start of Mixed-Up Doubles Tennis Tournament

### September

- 10 Women's Association Home Tour
- 11 Women's Association Cohoes Trip
- 20 Power Fleet Clambake

### October

- 12 Up-the-River
- 15 Women's Association Nature Hike
- 25 Children's Halloween Party

### November

- 8 Cups 'n Flags
- 15 Props 'n Shafts
- 19 Women's Association Estée Lauder Make-up Workshop

### December

- 6 Christmas Dinner Dance
- 10 Women's Association Annual Wine Tasting
- 11 RYC Annual Meeting
- 14 Children's Christmas Party
- 31 New Year's Eve Party

## 1980 RACING CALENDAR

### MAY

S	M	T	W	T	F	S
					1	2 3
4	5	6	7	8	9	10
11	12	13	14	15	16	17
18	19	20	21	22	23	24
25	26	27	28	29	30	31

### MAY

10	J-24 Fleet Tune-up Race
11	J-24 Fleet Spring Series, Race #1
17	J-24 Fleet Spring Saturday Series, Race #1
18	J-24 Fleet Spring Series, Race #2 Cruising Fleet Tune-up Race
23-June 5	US Olympic Selection Trials, Newport, RI
24	J-24 Fleet Spring Saturday Series, Race #2 Soling Fleet Tune-up Race
25	J-24 Fleet Spring Series, Race #3 Cruising Fleet Spring Series, Race #1 Soling Fleet Tune-up Race
26	Cruising Fleet Memorial Day Race Soling Fleet Memorial Day Race Dragon Fleet Memorial Day Race
28	Cruising Fleet Spring Wednesday Night Series, Race #1
31	J-24 Fleet Spring Saturday Series, Race #3 Soling Fleet Spring Saturday Series, Race #1 Laser Fleet Spring Series, Race #1

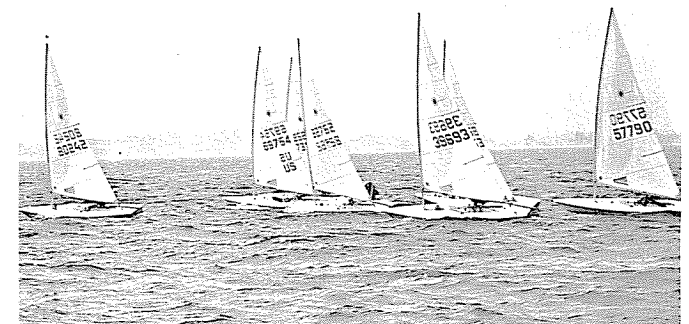

JUNE

S	M	T	W	T	F	S
1	2	3	4	5	6	7
8	9	10	11	12	13	14
15	16	17	18	19	20	21
22	23	24	25	26	27	28
29	30					

JUNE

- 1 J-24 Fleet Spring Series, Race #4  
Cruising Fleet Spring Series, Race #2  
Soling Fleet Spring Series, Race #1  
Dragon Fleet Spring Series, Race #1
- 4 Cruising Fleet Spring Wednesday Night Series, Race #2
- 7 J-24 Fleet Spring Saturday Series, Race #4  
Soling Fleet Spring Saturday Series, Race #2  
Laser Fleet Spring Series, Race #2
- 8 J-24 Fleet Spring Series, Race #5  
Cruising Fleet Spring Series, Race #3  
Soling Fleet Spring Series, Race #2  
Dragon Fleet Spring Series, Race #2
- 11 Cruising Fleet Spring Wednesday Night Series, Race #3
- 12 Ladies' Racing Association June Series, Race #1
- 14 J-24 Fleet Spring Saturday Series, Race #5  
Soling Fleet Spring Saturday Series, Race #3  
Laser Fleet Spring Series, Race #3  
GYC/RVC Course Race
- 15 J-24 Fleet Spring Series, Race #6  
Cruising Fleet Spring Series, Race #4  
Soling Fleet Spring Series, Race #3  
Dragon Fleet Spring Series, Race #3
- 18 Cruising Fleet Spring Wednesday Night Series, Race #4
- 19 Ladies' Racing Association June Series, Race #2

- 20 Genesee Yacht Club's Annual Scotch Bonnet Race,  
Cruising Fleet
- 21 J-24 Fleet Spring Saturday Series, Race #6  
Soling Fleet Spring Saturday Series, Race #4  
Laser Fleet Spring Series, Race #4
- 21, 22 Dragon Ottawa Regatta  
J-24 Fleet Niagara Frontier Invitational, Buffalo Canoe Club
- 22 J-24 Fleet Spring Series, Race #7  
Cruising Fleet Spring Series, Race #5  
Soling Fleet Spring Series, Race #4  
Dragon Fleet Spring Series, Race #4
- 25 Cruising Fleet Spring Wednesday Night Series, Race #5
- 26 Ladies' Racing Association June Series, Race #3
- 27-29 J-24 1980 District 7 Championship, Buffalo Canoe Club
- 27 Start of RVC Club Cruise  
Cruising Fleet Overnight Race to Fairhaven (tentative)
- 28 Soling Fleet Spring Saturday Series, Race #5
- 28, 29 Dragon Fleet Founder's Trophy Regatta, RVCYC
- 29 Soling Fleet Spring Series, Race #5  
Dragon Fleet Spring Series, Race #5
- 29, 30, July 1 Dragon Duke of Edinburgh Regatta, RVCYC

## 1980 RACING CALENDAR

JULY						
S	M	T	W	T	F	S
		1	2	3	4	5
6	7	8	9	10	11	12
13	14	15	16	17	18	19
20	21	22	23	24	25	26
27	28	29	30	31		

### JULY

3-5	Dragon North American Championship Regatta, RVYC
4, 5	J-24 Fairhaven Invitational, Fairhaven Marine
4-6	Soling Firecracker Regatta
	Dragon Great Lakes Championship
7-9, 13	Dragon Snapdragon Passage Race Series
9	Cruising Fleet Summer Series, Race #1
10	Ladies' Racing Association July Series, Race #1
10-13	J-24 E.Y.C. Regatta, Kingston Olympic Site
10-12	Dragon Henderson Harbor Regatta
11	Start of Lake Erie Race, Buffalo Yacht Club
12	J-24 Fleet Makeup Race
	Soling Fleet Summer Saturday Series, Race #1
	Laser Fleet Summer Series, Race #1
13	J-24 Fleet Makeup Race
	Soling Fleet Summer Series, Race #1
16	Cruising Fleet Summer Series, Race #2
17	Ladies' Racing Association July Series, Race #2
18	Start of Fairhaven/Main Duck Race, Fairhaven Yacht Club
19	J-24 Fleet Makeup Race
	Start of Port Huron-Mackinac Race, Bayview Yacht Club
	Soling Fleet Summer Saturday Series, Race #2
	Laser Fleet Summer Series, Race #2
20	J-24 Fleet Makeup Race
	Soling Fleet Summer Series, Race #2
	Dragon Fleet Summer Series, Race #1
23	Cruising Fleet Summer Series, Race #3
24	Ladies' Racing Association July Series, Race #3
25	J-24 Team Racing Invitational, Youngstown Yacht Club (tentative)
26, 27	Youngstown Yacht Club Level Regatta, Youngstown
26	Start of Chicago-Mackinac Race, Chicago Yacht Club
	Soling Fleet Summer Saturday Series, Race #3
	Laser Fleet Summer Series, Race #3
27	Soling Fleet Summer Series, Race #3
	Dragon Fleet Summer Series, Race #2

## 1980 RACING CALENDAR

AUGUST						
S	M	T	W	T	F	S
					1	2
3	4	5	6	7	8	9
10	11	12	13	14	15	16
17	18	19	20	21	22	23
24	25	26	27	28	29	30
31						

### AUGUST

2	Soling Fleet Summer Saturday Series, Race #4
	Ladies' Racing Association August Series, Race #1
	Laser Fleet Summer Series, Race #4
2, 3	Dragon Fleet Mayor's Trophy Regatta
3	Start of Freeman Cup Race, Port Credit Yacht Club
	Soling Fleet Summer Series, Race #4
5-7	LYRA Course Racing, Cruising Fleet, Hamilton Yacht Club
8	Cruising Fleet Centennial Race, Hamilton to Toronto
9	Richardson Cup Eliminations, Toronto
	Soling Fleet Summer Saturday Series, Race #5
	Laser Fleet Summer Series, Race #5
	Ladies' Racing Association August Series, Race #2
	Dragon Hawgood Trophy Regatta, RCYC
10	Soling Fleet Summer Series, Race #5
	Dragon Fleet Summer Series, Race #3
16	J-24 Fleet Fall Saturday Series, Race #1
	Start of Lake Ontario International, Toronto
	Soling Fleet Fall Saturday Series, Race #1
	Ladies' Racing Association August Series, Race #3
17	J-24 Fleet Fall Series, Race #1
	Soling Fleet Fall Series, Race #1
	Dragon Fleet Summer Series, Race #4
20	Cruising Fleet Summer Series, Race #4
23	J-24 Fleet Fall Saturday Series, Race #2
23-29	C.O.R.K. — Solings
24	Cruising Fleet Summer Series, Race #5
24	J-24 Fleet Fall Series, Race #2
	Dragon Fleet Summer Series, Race #5
27	Cruising Fleet Summer Series, Race #6
28-31	Royal Canadian Week of Level Racing, RCYC
30	Cruising Fleet Labor Day Race to Sodus Bay Yacht Club
30, 31, Sept. 1	J-24 1980 Great Lakes Championship
	Soling Great Lakes Championship
	Dragon Cleveland Regatta, E.Y.C. (tentative)

## 1980 RACING CALENDAR

### SEPTEMBER

S	M	T	W	T	F	S
	1	2	3	4	5	6
7	8	9	10	11	12	13
14	15	16	17	18	19	20
21	22	23	24	25	26	27
28	29	30				

### SEPTEMBER

- 1 Cruising Fleet Labor Day Race, Sodus Bay Yacht Club to Rochester Yacht Club
- 3 Cruising Fleet Fall Wednesday Night Series, Race #1
- 6 J-24 Fleet Fall Saturday Series, Race #3  
Dragon Bay Series, RCYC
- 6, 7 Solings—Youngstown Regatta, Youngstown Yacht Club
- 7 J-24 Fleet Fall Series, Race #3  
Cruising Fleet Fall Series, Race #1  
Dragon Fleet Fall Series, Race #1
- 10 Cruising Fleet Fall Wednesday Night Series, Race #2
- 13 J-24 Fleet Fall Saturday Series, Race #4  
Soling Fleet Fall Saturday Series, Race #2
- 14 J-24 Fleet Fall Series, Race #4  
Cruising Fleet Fall Series, Race #2  
Soling Fleet Fall Series, Race #2  
Dragon Fleet Fall Series, Race #2
- 17 Cruising Fleet Fall Wednesday Night Series, Race #3
- 20 J-24 Fleet Fall Saturday Series, Race #5  
Soling Fleet Fall Saturday Series, Race #3
- 21 J-24 Fleet Fall Series, Race #5  
Cruising Fleet Fall Series, Race #3  
Soling Fleet Fall Series, Race #3  
Dragon Fleet Fall Series, Race #3
- 27 J-24 Fleet Fall Saturday Series, Race #6  
Soling Fleet Fall Saturday Series, Race #4
- 28 J-24 Fleet Fall Series, Race #6  
Cruising Fleet Fall Series, Race #4  
Soling Fleet Fall Series, Race #4  
Dragon Fleet Fall Series, Race #4

## 1980 RACING CALENDAR

### OCTOBER

S	M	T	W	T	F	S
		1	2	3	4	
5	6	7	8	9	10	11
12	13	14	15	16	17	18
19	20	21	22	23	24	25
26	27	28	29	30	31	

### OCTOBER

- 2 Dragon Fleet Fall Series, Race #5
- 4 J-24 Fleet Fall Saturday Series, Race #7  
Soling Fleet Fall Saturday Series, Race #5
- 5 J-24 Fleet Fall Series, Race #7  
Cruising Fleet Fall Series, Race #5  
Soling Fleet Fall Series, Race #5
- 9 Dragon Fleet Fall Series, Race #6
- 12 Cruising Fleet Makeup or Bottle of Bourbon Race
- 16 Dragon Fleet Fall Series, Race #7



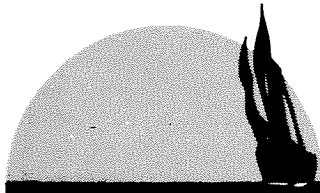

## ROCHESTER YACHT CLUB

### 1980 SAILING INSTRUCTIONS

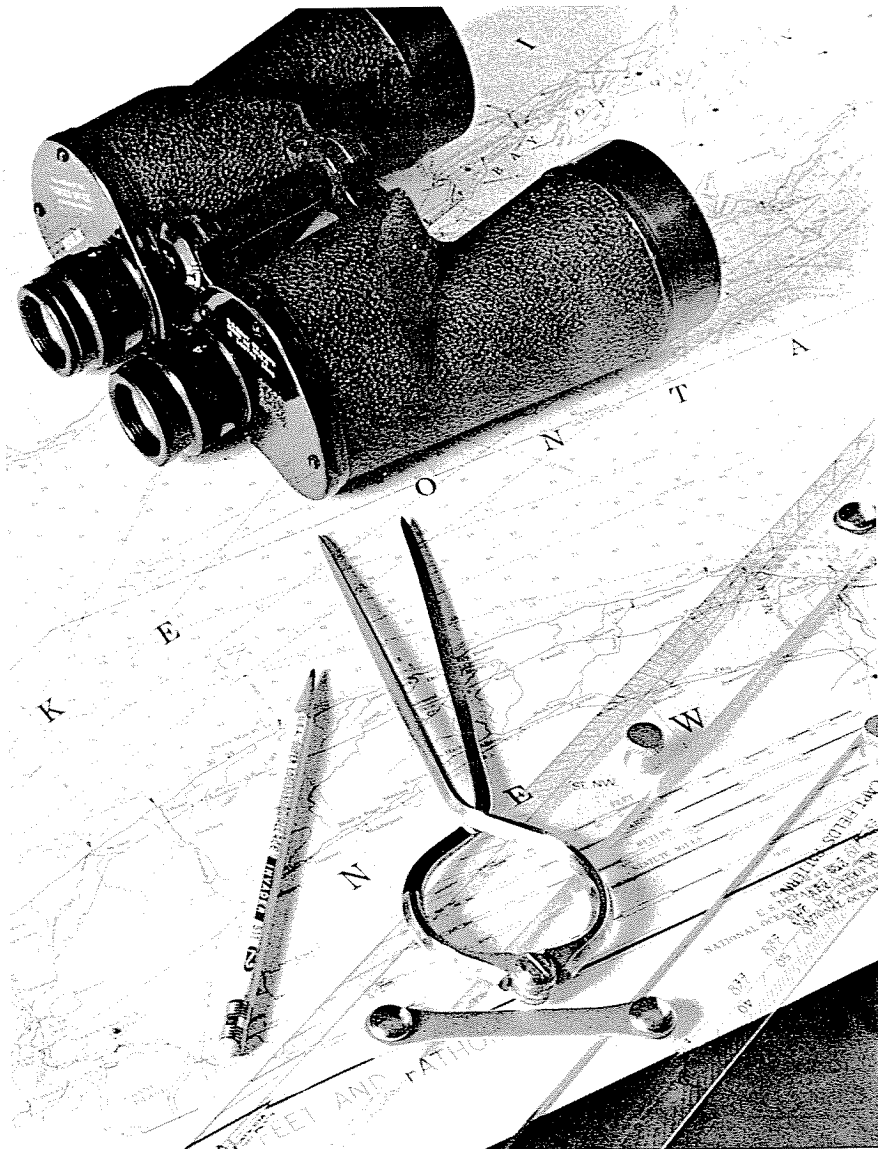

## 1. GENERAL SAILING INSTRUCTIONS

1.1 **SCOPE**—These sailing instructions apply to course races sailed on the Olympic Circle or cruising fleet course and normally a part of R.Y.C. recognized series. Supplemental sailing instructions may be required for regattas, distance races, and all other course racing.

1.2 **RULES**—Races governed by these sailing instructions are conducted under the International Yacht Racing Union Rules as adopted by U.S.Y.R.U. and specifically set forth in the "1977 Yacht Racing Rules". Class rules shall be treated as part of the sailing instructions.

1.3 **ADMINISTRATION**—Each Fleet Captain will maintain a complete fleet roster showing each skipper, yacht, and racing number. The fleet will specify the particular scoring system for his/her fleet. It is the Fleet Captain's responsibility to score each race and post the results.

1.4 **PROTESTS**—Protests will be heard at the R.Y.C. Clubhouse at 1700 hours on Sunday during the regular racing season. Special protest meetings may be called by the chairman of the Protest Committee upon reasonable notice to all parties. All protests must be submitted in writing within one hour after the return of the yacht to the basin or its other area mooring. A depository for protests will be located at the Clubhouse liquor service counter. Each protest must contain the date and time it is placed into the depository with such information attested to by the signature of the bartender on duty. Failure to incorporate this information on the form will void the protest. The standard U.S.Y.R.U. protest form (available from fleet captains, protest committee or at the liquor service counter) should be used. Written protests as prescribed in rule 68.3 (d) are also acceptable.

1.4.1 **ALTERNATIVE PENALTIES**—Alternates to disqualification for infringement of a rule as required by the 1977 Yacht Racing Rules on protests are included within these instructions as prescribed by Rule 3.2 (b) XIV.

1.4.1a **720° TURNS**—A yacht of any class which acknowledges infringing a rule of Part IV may exonerate herself by making two full 360° turns (720°).

1.4.1b **SAFETY REQUIREMENTS**—A time or position penalty as uniformly defined by the R.Y.C. Protest Committee shall be assessed any yacht which infringes upon the safety requirements of her fleet.

1.5 **CREW**—Regular crew members of boats participating in class races shall be members of the Rochester Yacht Club, Junior Yacht Club, or the immediate family of an R.Y.C. member.

1.6 **RACING PROGRAM**—The racing program consists of:

- (1) Saturday afternoon racing with three starts for one-design classes.
- (2) Sunday racing with five cruising fleet division starts and three one-design starts.
- (3) Wednesday night racing with one-design and cruising fleet starts as required.

(4) Additional programs are available for Laser's, 420's, and Ladies Racing Association as specified in separate individual sailing instructions.

1.7 **STARTING TIMES**—The starting times contained in Appendix A of the General Sailing Instructions are the scheduled times for the firing of the Starting gun. Warning and Preparatory guns will each be fired at five minute intervals. The committee boat will be on station at the starting buoy five minutes before the first Warning gun.

1.8 **STARTING SIGNALS**—All signals shall be in accordance with Rule 4, except those starting signals contained in the Appendix A hereof shall replace those given in Rule 4.4 (a) of the 1977 Yacht Racing Rules.

1.9 **GENERAL RECALL**—All signals for a general recall shall be in accordance with rules 4.1 and 4.7 of the 1977 Yacht Racing Rules. The offending fleet shall immediately retire from the race area to await a restart. Such restart shall occur five minutes after the scheduled starting sequence for all divisions or fleets has been completed. For example, if a cruising fleet division is recalled, they will be restarted five minutes after the last scheduled cruising fleet division. If more than one division is recalled, they will be restarted at five minute intervals in the order in which they occurred. If the last scheduled division is the *only* division recalled, then a new warning signal shall be made one minute after the general recall signal has been lowered. The same procedure applies to the one-design fleets.

1.10 **POSTING**—Official notices subscribed to by the Sailing Committee chairman or the Race Committee chairman and race results will be posted on the Race Committee bulletin board located in the gas dock area. All official notices affecting races of the day will be posted two hours prior to the first scheduled start of that day. It is the responsibility of each skipper to check the bulletin board prior to leaving the R.Y.C. basin for each day's racing.

1.11 **AMENDMENTS**—All changes to the Sailing Instructions shall be in writing subscribed to by the Sailing Committee chairman and posted on the Race Committee bulletin board. An amendment will not be effective until posted a minimum of 24 hours. A copy of any amendment will be mailed to each racing skipper for incorporation with his Sailing Instructions.

## 2. CRUISING FLEET SAILING INSTRUCTIONS

These instructions apply in addition to the General Sailing Instructions of Section 1.

### 2.1 COURSES

2.1.1 **SPRING AND FALL SUNDAY SERIES AND SPRING TUNE UP (EXCEPT REGATTA RACE)**—The course shall be a closed triangle shown on the cruising fleet course chart. All distances shown are in nautical miles and all headings in degrees magnetic. The starting and finishing area is at mark "O" (the center of the olympic circle). It is a tri-colored mark identified by the letter O. All races on this course start and finish at or near mark O. The starting line is from the white flag on the committee boat to mark O. The finish line is between the blue flag on the committee boat and the nearby red flag mark set daily in the finish area near mark O. The race course will be selected by the race committee and identified by listing the marks to be rounded in the order they are to be taken. Example: D-B-A is a triangular course, buoys to starboard, to the departure buoy D, direct to the west mark B, to the north east mark A, and back to finish near mark O. The committee boat will post the mark rounding sequence at least five minutes before the first warning signal and maintain that course through the entire starting sequence for each fleet. The race committee may only change courses between fleet starts and only as prescribed in Rule 4.3. Skippers are encouraged to monitor VHF Channel 9 for race committee broadcasts of the mark rounding sequence which defines the course to be sailed. The race committee will also endeavor to use channel 9 to broadcast sail numbers of boats over early. In all cases visual signals shall govern. All marks are Coast Guard approved orange and white striped and have a letter corresponding to their position on the chart painted on the buoy. In the event a mark for the day's race course is missing, an attempt will be made to replace it with a large orange inflatable "regatta" mark or another type of mark to which the code flag M is attached. When one of these marks is placed near the normal position of a fixed fleet mark *it shall rank as a mark of the course* and be rounded by all yachts. Any other mark in the vicinity shall be disregarded.

2.1.2 **SPRING AND FALL WEDNESDAY NIGHT RACES**—The starting and finishing area for the Wednesday night races is near the departure buoy (D buoy). The course shall be an out and back course in which one mark is rounded. The minimum course length shall be 4 nautical miles. The starting line is from the D buoy to the white flag on the Committee boat. The finish line is from the D buoy to the flashing light atop the committee boat. The rounding mark will display a red flag, be lighted if required, and set out a distance and direction signaled by the committee boat. The Committee boat will display a red or green flag indicating the hand of rounding. Example: 4-075 green would signal a 4 nautical mile out and 4 nautical mile

back course with a mark lying 075° magnetic from the Committee boat to be left to starboard.

**2.1.3 REGATTA COURSE**—Selected races during any series may be identified as Regatta races. For a regatta race, no fixed course is used, rather, a course is set for the day's racing using the large inflatable "regatta" marks. The general starting area for this race will be as near Mark O as practical. The diagram below shows the course.

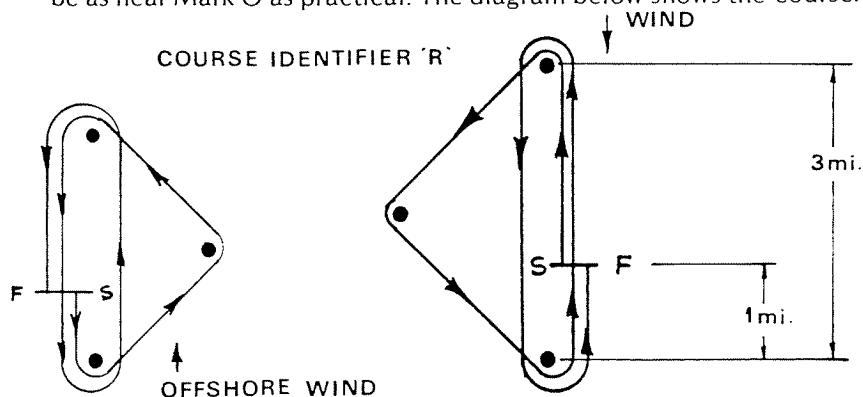

The following rules apply to the regatta course.

1. All buoys left to *Port*
2. Starting line at S—(Permanent buoy).
3. First leg is always to weather.
4. A 90° included angle-to-course lines is formed at reaching mark.
5. The two reaching legs of the triangle are equal length.
6. The finish leg is to weather.

The Committee Boat will signal the length of the weather leg, the magnetic heading to weather mark, and the letter R. No other signals will be given to identify the course.

**2.1.4 SUMMER RACE COURSES** by specific announcement.

## 2.2 COURSE ALTERATIONS

**2.2.1 SHORTENING COURSE**—Races on the R.Y.C. cruising fleet course may be shortened by establishing a finish line as prescribed in Rule 4.5 at any mark of the course prior to the first boat rounding. The signals given in Rule 4.1 shall be used. The Wednesday night course once established shall not be shortened. The regatta course may be shortened by establishing a finish line at the leeward mark or at the weather mark after the first rounding.

**2.2.2 MOVING THE WEATHER MARK**—After all yachts have completed the first leg of a regatta course, the weather mark may be moved to provide a better (more symmetrical) second beat. The new course heading to the relocated weather mark will be announced and the magnetic heading displayed prior to the first yacht rounding the leeward mark.

**2.3 TIME LIMITS**—A race will be official if any yacht finishes within the time limit for that race plus her time allowance for the course being sailed. Time will be counted from the start of P.H.R.F. 1 yachts, for the P.H.R.F. divisions, and from I.O.R. 1, start for the I.O.R. divisions.

### TIME LIMIT TABLE

Tune Up	5 hours
Spring Sunday	5 hours
Spring Wednesday Night	2½ hours or 2 hours to first mark
Summer Series	To be announced
Fall Series	5 hours
Fall Wednesday Night	2½ hours or 2 hours to first mark

**2.4 SCORING**—Scoring will be low point with a yacht's score in a race being equal to her finish position. A yacht which starts and does not finish, or which ranks as a starter in accordance with Rule 50, Ranking as a Starter, but does not start, or which fails to sail the course correctly in accordance with Rule 51, Sailing the Course, or which infringes the rules but retires within a reasonable time, shall score points equal to the number of boats ranking as a starter; i.e., for the finishing place equal to the number of yachts which started or ranked as starters in accordance with Rule 50 in that race.

Except as provided above, a yacht which infringes the rules but does not retire within a reasonable time, or which is disqualified under Rule 72, Disqualification after Protest, or Rule 73, Disqualification without Protest, shall score the points for a last place finish plus 10 percent of the number of yachts ranked as starters in accordance with Rule 50, in that race, fractions being raised to the next higher whole number. A yacht which neither starts, nor ranks as a starter in accordance with Rule 50, shall score points for the finishing place equal to the maximum number of competitors in any previous race of the series. A competitor is an entrant who starts, or ranks as a starter in accordance with Rule 50, in any race for the series. Should there be a tie on total points between two or more yachts, the tie shall be broken using the "Horse Race" Method. If this fails, the tie shall be broken in favor of the yacht or yachts with the most first places, and should any such yachts remain tied, the most second places and so on. Should any tie then be unresolved, the tie shall stand as the final placing of the series. All races will be scored on a divisional basis with at least four boats required in a division for a particular race to qualify for that division.

**2.5 ADMINISTRATION**—It is the responsibility of each skipper to check the official race committee bulletin board for announcements before leaving the basin.

The decision as to whether or not to start a race will be made by the race committee. If a race has been cancelled, the code flag C will be flown from the Club mast as soon as possible.



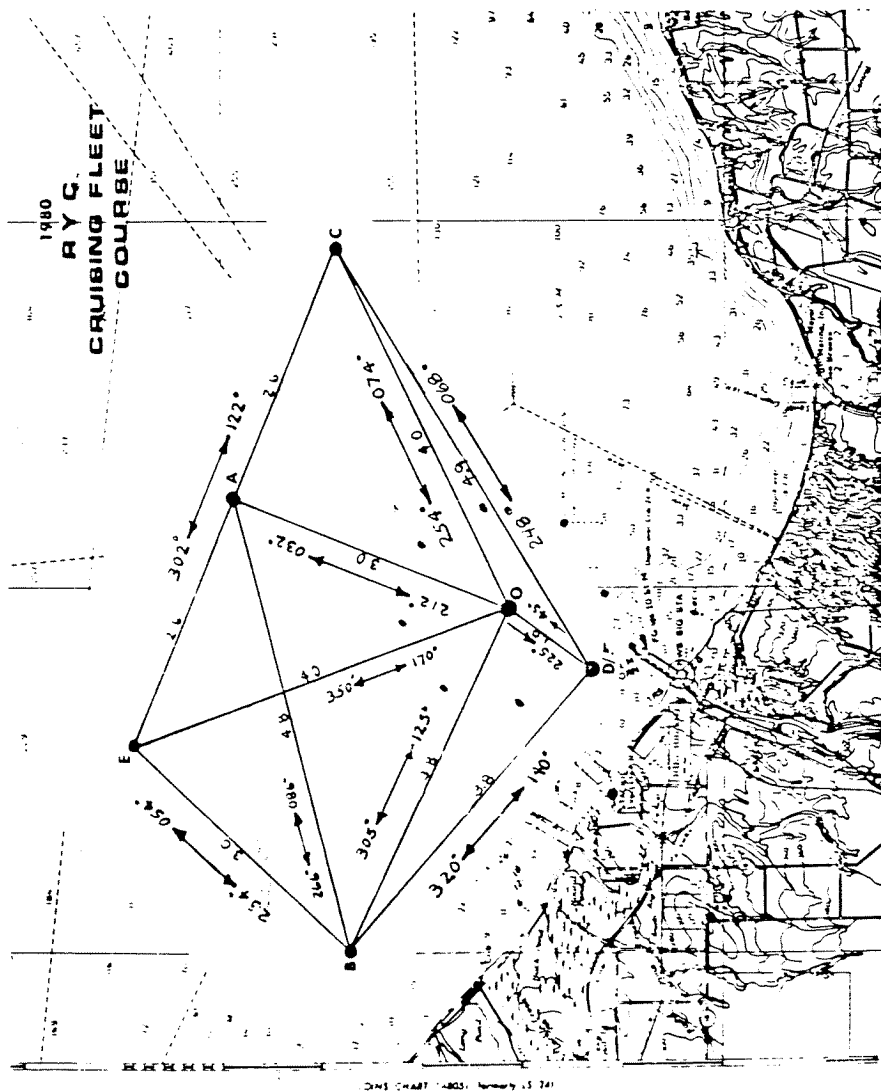

To be eligible for awards for a series, a yacht must have filed a racing certificate with the fleet captain in a satisfactory manner. Finish positions will not be posted for skippers who have not satisfied this requirement.

Yachts are subject to disqualification for sailing in the starting area when other yachts are maneuvering to start. Maneuvering to start normally means sailing during the period of time from a yacht's warning gun to the starting gun.

**APPENDIX A**

**STARTING SIGNALS**

Day	Hour	Flags(s)	Warning	Preparatory	Start
Saturday	1300	W	J/24		
	1305	P		J/24	
	1310	6			J/24
	1320	W	SOLING		
	1325	P	DRAGON	SOLING	
	1330	7		DRAGON	SOLING
	1335	8			DRAGON
	1335	8			
Sunday	0950	W	DIVISION V		
	0955	P		DIVISION V	
	1000	1	DIVISION IV		DIVISION V
	1005	B		DIVISION IV	
	1010	2	DIVISION III		DIVISION IV
	1015	C		DIVISION III	
	1020	3	DIVISION II		DIVISION III
	1025	D		DIVISION II	
	1030	4	DIVISION I		DIVISION II
	1035	E		DIVISION I	
	1040	5			DIVISION I
	1055	W	J/24		
	1100	P	SOLING	J/24	
	1105	6	DRAGON	SOLING	J/24
	1110	7		DRAGON	SOLING
1120	8			DRAGON	
Wednesday	1820	W	J/24		
	1825	P		J/24	
	1830	1	DIVISION III		J/24
	1835	B		DIVISION III	
	1840	2	DIVISION II		DIVISION III
	1845	C		DIVISION II	
	1850	3	DIVISION I		DIVISION II
	1855	D		DIVISION I	
	1900	4			DIVISION I

Check the bulletin board by the gas dock for amendments.

**APPENDIX B  
RYC CRUISING FLEET  
SAFETY REQUIREMENTS**

1. Seacocks or valves on all through-hull openings, except integral deck scuppers, shft logs, speedo transducers, etc.; however a means must be provided for closing such openings when necessary.
2. Soft wooden plugs, tapered and of various sizes.
3. Fixed bow pulpit.
4. Taut single life-lines.
5. All ballast and other heavy equipment such as batteries, stoves, gas bottles, tanks, and outboard motors must be securely fastened in position.
6. Permanently installed toilet, bunks and galley facilities.
7. Fire extinguishers as required by law.
8. One manual bilge pump capable of being operated with all cockpit seats and all hatches and companionways closed.
9. One anchor and cable.
10. At least one water-resistant flashlight with spare batteries and bulb.
11. First aid kit *with* manual.
12. Foghorn and radar reflector.
13. Shutoff valves on all fuel tanks.
14. Compass, marine type, properly installed and adjusted.
15. Lead line or echo sounder.
16. Navigation lights shown as required by law, mounted so that they will not be masked by sails.
17. Tools and spare parts, including rigging cutters or hacksaw.
18. Heavy weather jib and reefing equipment on mainsail.
19. Radio receiver capable of receiving weather bulletin.
20. One life jacket for each crew member.
21. At least one horseshoe-type life ring equipped with waterproof light and drogue within reach of the helmsman and ready for instant use.
22. The following distress signals and launcher:
  - a. Three red aerial flares.
  - b. Three red hand flares.
  - c. Two orange hand smoke flares.
23. Heaving line (50 foot minimum length, floating-type line) readily accessible to cockpit.
24. USYRU Racing Rule Book.
25. Emergency steering equipment.
26. High intensity automatic water light for horseshoe-type life ring (for night races only).
27. Man overboard pole (height of flag at least 4 feet above water).

All equipment must function properly, be readily accessible, and be of a type, size and capacity suitable and adequate for the intended use and the size of the yacht.

**The following equipment required for long-distance races (Presqu'île and Sodus):**

1. Taut double life-lines, with stern pulpit.
2. One extra manual bilge pump.
3. Spare compass, charts, light list and piloting equipment.
4. Speedometer or distance measuring equipment.
5. Yacht's name on miscellaneous buoyant equipment such as life jackets.
6. Whistles attached to life jackets.
7. Safety harnesses for each crew member.
8. "Life raft" meeting the following requirements:
  - a. Must be capable of supporting the entire crew.
  - b. Must have integral, inflated buoyancy compartments.
  - c. Must be inflated via attached cylinder, or carried inflated on deck, and securely fastened.

**NOTE:** Yachts may be inspected either before or after any RYC scheduled race and are required to carry the above safety gear when racing.

**OWNER'S RESPONSIBILITY**

The safety of a yacht and her crew is the sole and inescapable responsibility of the owner, who must do his best to ensure that the yacht is fully found, thoroughly seaworthy and manned by an experienced crew who are physically fit to face bad weather. He must be satisfied as to the soundness of hull, spars, rigging, sails and all gear. He must ensure that all safety equipment is properly maintained and stowed and that the crew know where it is kept and how it is to be used.

Neither the establishment of these special regulations, their use by sponsoring organizations, nor the inspection of a yacht under these regulations in any way limits or reduces the complete and unlimited responsibility of the owner.

It is the sole and exclusive responsibility of each yacht to decide whether or not to start or continue to race.

### 3. ONE-DESIGN SAILING INSTRUCTIONS

These instructions relate to the Dragon, Soling and J/24 fleets and apply in addition to the General Sailing Instructions of Section 1.

3.1 **COURSES** — All races will be sailed on the R.Y.C. Olympic Circle which will be set as shown below. The diameter of the circle is two statute miles north, its center at the tri-colored mark (mark 0). All races will start and finish between the committee boat and mark 0. The race committee will display a card designating the type of course to be sailed (W, T, TW, G) and a number designating the first mark of the course. All buoys shall be left to port except on finishing on occasion. Appendix A, hereto, illustrates the Olympic Circle and sailing courses. The course for the first race will be a T (triangle). The course for the second race will be at the option of the race committee, preferably a TW or G.

3.2 **SECOND RACES** — The starting sequence for the second race will begin as soon after the last boat from the first fleet to finish as is convenient for the race committee. The starting signals for the second race will consist of a two flag system to help distinguish which fleet is in its starting sequence. In addition to the "W" flag for the ten minute warning signal and the "P" flag for the five minute preparatory signal a numeral will be displayed to designate the fleet to be started next. The numeral designations shall be as follows:

Signal Flag	Fleet
6	J/24
7	Soling
8	Dragon

FOR EXAMPLE: The display of the code flags (W, 6) would indicate 10 minutes to a J/24 start, (P, 7) would indicate five minutes to a soling start, (P, 8) would indicate five minutes to a dragon start, etc. If the last boat of a particular fleet finishes before the preparatory signal of a fleet in its starting sequence, then that fleet shall start five minutes after the first fleet. The same procedure shall apply for any subsequent fleets. If the last boat finishes after the preparatory signal then they will be started at the discretion of the race committee.

3.3 **TIME LIMITS** — The time limit for all races is three hours. An effort will be made to sail two races on Saturday and two on Sunday. No Saturday race will be started after 1530 hours. No Sunday race will be started after 1330 hours.

### APPENDIX A

#### ONE-DESIGN RACE COURSE

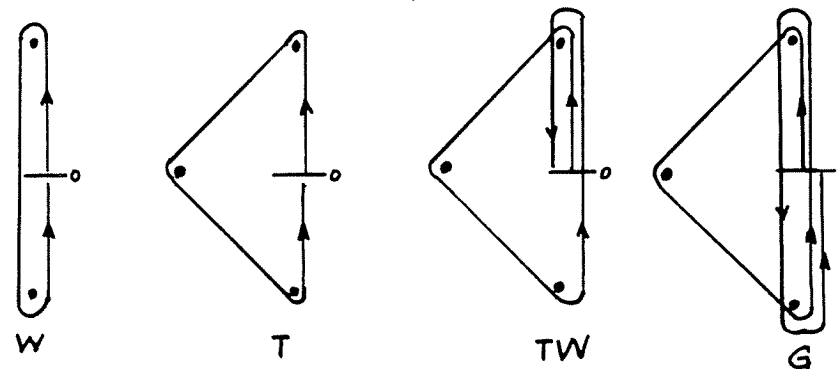
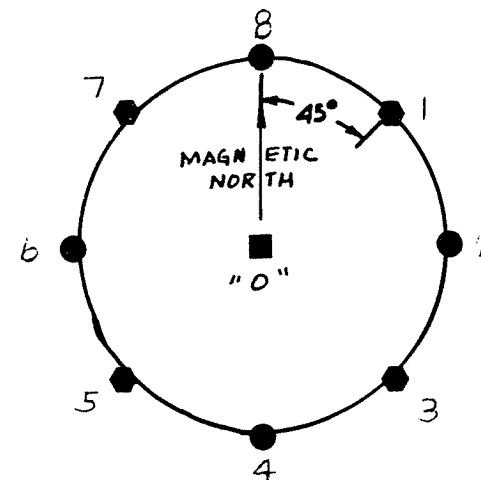

### 3.4 SOLING SCORING PROCEDURE

#### 3.4.1 SERIES STANDINGS

1. There are 6 separate series per year. (Spring/Summer/Fall, Saturday/Sunday)
2. Each series is scheduled for **10** races.
3. In series competition, the **boat** is scored, regardless of skipper.
4. Each race is scored as follows:
  - a) N is defined as the number of boats in the fleet + 1.
  - b) The 1st place boat in a race is given  $N + \frac{1}{4}$  points. 2nd place boat in a race is given (N-1) points. 3rd place boat, (N-2) points, etc. The general form for points in a race is  $(N - pl + 1)$  where pl = place finished. In addition, 1st place boat gets an extra  $\frac{1}{4}$  point.
5. A boat's score is accumulated within a series by adding the points for each race.
6. In the event that more than 5 races in a series are held, there are throwouts allowed.

Races Sailed	Throwouts Allowed
6, 7	1
8, 9	2
10	3

7. All races not sailed by a boat in a series accumulate 0 points.

#### 3.4.2 SOLING SEASON STANDINGS

1. Season standings are based on races in which the skipper/owner sailed the boat.
2. To qualify for any of the 3 season categories (Sat./Sun./overall), the skipper must have sailed at least 50% of the races in that category.
3. There are **NO** throw-outs.
4. Points are decided by the ratio of points accumulated in each category to total points possible for the number of races counted. Highest ratio wins.

### 3.5 J/24 FLEET SCORING SYSTEM

#### 3.5.1 SERIES SCORING SYSTEM

1. *FOUR SERIES will be held in a season:*
  - Spring Saturday — 14 races per series (7 days, 2 per day)
  - Spring Sunday — 14 races per series (7 days, 2 per day)
  - Fall Saturday — 14 races per series (7 days, 2 per day)
  - Fall Sunday — 14 races per series (7 days, 2 per day)(No Summer series, to allow for Wednesday Night Fleet "fun" or "crew" races, Sunday cruising class races, out of town regattas and family cruising.)

2. Score the RYC resident member boat owner ("skipper"), but up to a 20% substitution of races by non-owner skippers can occur in a series to encourage Fleet interest and growth (Round any fractions upward).

3. *The highest number of points win.*

4. *Points are to be earned as follows:* (Essentially, one point for starting, finishing and each boat beaten)

1st place: Number of boats\*, plus "1", plus " $\frac{1}{4}$ " bonus point;

2nd place: Number of boats\*, only;

3rd place: Number of boats\*, minus "1";

4th place: Number of boats\*, minus "2";

5th place: Number of boats\*, minus "3";

etc.

\* (Number of RYC-registered J/24's in the Fleet on the date of the first race in that series or actual number of boats scored in a given race, whichever number is greater.)

5. *DNF's* earn 1 point.

6. *DSQ's* earn  $\frac{1}{2}$  point.

7. *Throw-outs:* If 11 races or less are held in a series — no throw-outs; 12 races — 1 throw-out; 13 races — 2 throw-outs; 14 races — 3 throw-outs. (This "enables" missing one of 7 weekends in a series plus one "bad" or "breakdown" race without penalty.)

8. Any ties in a series are to be broken by ignoring the 1st throw-outs (i.e., least favorable race) — then 2nd, etc., until the tie is broken.) *Thereafter*, the skipper with the greatest number of "firsts" is the winner; *Thereafter*, the greatest number of "seconds", ETC., until the tie is broken.

9. *USYRU, J/24 Class and RYC Rules* apply, EXCEPT as amended by  $\frac{3}{4}$  of the Fleet skippers (one vote per boat) or modified by the *Fleet Captain(s)* on prior notice.

10. A resident member of RYC (or spouse or family member under 19 years of age) must be on board any boat in order to be scored and that member will be fully responsible for rules compliance and the boat. Fleet dues must be paid in full prior to any race being scored.

11. To be scored, all boats must have a commercial grade of permanent bottom paint on 100% of the hull below the waterline. Dry-sailing of boats is to be highly discouraged and will not be permitted unless absolutely required by limited RYC and local dockage facilities.

3.5.2 **OVERALL CHAMPIONSHIP SCORING SYSTEM** — Saturday Series, Sunday Series & Season Championships (3)

1. *The RYC resident member boat owner ("skipper") (or skippers as one "partnership" entity if a co-owned boat) and not the boat is scored in this one-design system.*

2. *A percentage basis applies for all three "overalls" (i.e., Saturday, Sunday & Season) — (points determine the four individual series championships).*

3. *75% or more of the races in a particular series (i.e., Saturday or Sunday) must be raced by the skipper to be eligible for overall series championships (i.e., 21 out of 28 races if 28 races are held in a season for that series). (Round any fractions upward.)*

4. *66-2/3% or more of the races for all series (i.e., Fall Saturday and Sunday, and Spring Saturday and Sunday) — and not regattas — must be raced to be eligible for the season's overall fleet championship (i.e., 38 races out of 56 races if 56 races are held in the season). (Round any fractions upward.)*

5. *The highest percentage decimal wins the series or the season overall championship.*

6. *Percentage decimals shall be computed by dividing the numerator by the denominator, as follows:*

A) *Numerator:* The total actual number of points accumulated by a skipper in a series (after throw-outs).

B) *Denominator:* The total number of points accumulated had a skipper been first in all races counted in a series (the "number of boats" in this computation shall be the largest number of J/24's in the Fleet at any one time during that season).

7. *The season overall championship shall be determined in a like manner, considering points earned and "earnable" for all series (i.e., Saturday and Sunday points computed as a single series).*

8. *This system is designed around four strong (Spring and Fall, Saturday and Sunday) series of a maximum of 56 races in the season. Seven successive weekends per series would be raced where possible. If racing cannot be held on a scheduled date, that date would be made up on the next successive weekend after the last scheduled race of that series, but in no event shall more than one full additional weekend be utilized for make-ups in a series.*

9. *Season trophies and flags will be as follows: Season Championship, Saturday Series Overall, Sunday Series Overall, Spring Saturday Series, Spring Sunday Series, Fall Saturday Series, Fall Sunday Series. (The first three places in all of the above will earn flags, as well, provided RYC makes such flags available.)*

3.6 **DRAGON FLEET SCORING SYSTEM**

Place	Points
First	3/4
Second	2
Third	3
Fourth	4
Fifth	5
Etc.	and so on

DNS — Number of yachts in series, determined at series end.

DNF — Number of yachts starting race.

DSQ — Number of yachts in series plus one.

3.6.1 *Substitute skippers.* Score for race is average of other starts.

3.6.2 *Drop Races.*

1. *Poorest finish is dropped from series scoring after six races are sailed.*

2. *Second poorest finish is dropped if ten races are sailed in the series.*

3. *Substitute skipper finishes are dropped first.*

3.6.3 *Ties.* Ties will be broken in favor of yacht with (1) most first place finishes, (2) most second place finishes, etc., (3) higher number of finishes (placed ahead more times), or (4) higher finish in last race.

3.6.4 *Fleet Champion.* Skipper with best average for RYC races he sailed, and which were counted in any series. To be eligible, skipper must have sailed in at least half of the races sailed.

## 4. LASER FLEET SAILING INSTRUCTIONS

These instructions apply in addition to the General Sailing Instructions of Section 1.

4.1 **RULES** — The current yacht racing rules of the International Yacht Racing Union as adopted by the United States Yacht Racing Union shall govern. The Rules of Laser shall apply.

4.2 **SCORING**—To qualify, a boat must sail in half as many races as the boat that sails in the most races of a series. The winning boat shall be the one with the highest percentage scored at the end of the season or series. The percentage shall be: The number of points scored divided by the number of points a boat could have scored (i.e. the number of boats in the race that she sails in). A boat shall receive one point for starting and one point for each boat she beats.

“Did not Finish” — One Point      “Did not Start” — Not Scored  
 “Withdrawn” — One Point          “Disqualified”— Minus Two Points

4.3 **COURSES SIGNALS** — The diagram with identifying letters shown indicate types of courses to be sailed. The identifying code flag will be displayed from the committee boat before or with the warning signal.

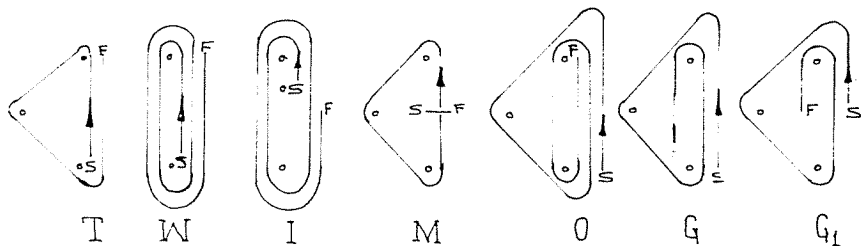

- T — Triangle
- W — Windward and Leeward
- I — Windward, Leeward and Windward
- M — Triangle with start and finish in middle of leg
- O — Triangle followed by windward, leeward and windward (Olympic)
- G — Triangle followed by windward and leeward (modified Gold Cup) “G” with start and finish in middle of leg.

4.4 **ATTENTION SIGNAL** — One gun *One Hour* before start.

4.5 **STARTING AND FINISHING LINE** — The line will be between the white flag on the Committee Boat and the mark. A blue shape will be displayed when the committee boat is on station at the finish line.

4.6 **STARTING SIGNALS** — Warning signal — White shape — hoisted 6 minutes before the start. Preparatory Signal — Blue shape — hoisted 3 minutes before the start.

Starting Signal — Red shape — hoisted.

Each signal will be lowered thirty seconds before the hoisting of the next.

Attention to Starting Signals will be called by firing a gun.

4.7 **RECALL** — A white shape with red horizontal band, accompanied by one blast for each yacht recalled. The Committee will endeavor to notify each yacht recalled by hailing, but it is the responsibility of each yacht to make a proper start.

4.8 **GENERAL RECALL** — Hoisting of First Repeater (yellow triangle on blue background) and firing two guns. Upon lowering of First Repeater, there will be one long horn blast. Preparatory will be made 30 seconds after lowering. 1 minute rule shall be in effect on a General Recall Rule 51.1 (C).

4.9 **SHORTENING COURSE** — Hoisting of code flag S (white with blue square) and firing two guns. Finish between white flag on Committee Boat and the nearby rounding mark.

4.10 **MARK MISSING** — Hoisting of code flag M (white diagonal on blue field) and firing of one gun. Round or pass the object displaying this signal instead of the mark which it replaces.

4.11 **POSTPONEMENT** — Hoisting of Answering Pennant (AP — red and white vertical bars) and firing two guns: postponement will be in five minute intervals and will end at the lowering of the Answering Pennant. One minute before the warning gun and the warning signal. Postponement can be extended indefinitely with the addition of a number pennant under an AP with one number for every 15 minutes, except No. 4 — postponement for one hour.

4.12 **ABANDONMENT** — Abandoned for the day, code flag N (blue and white checks) over code flag X (white with blue cross) and firing three guns.

4.13 **PROTESTS** — A yacht wishing to protest *must promptly* hail loudly using the word “Protest”, and also notify the Race Committee of her intention, while the committee is still on the Finish Line. Upon returning to the Club House, a written protest must be filed with the Race Committee, on forms to be obtained in the Club House. The written protest *must* be filed no later than one hour after the Race Committee returns to the dock. The Race Committee will fire one gun when they return to the dock, if any protests have been entered at the committee boat. Protest meetings will be held as soon as possible after the racing is over for the day. The time and place for holding protest hearings will be announced. Such announcement shall be deemed notification of all parties concerned and the hearings will not be delayed while waiting for the parties concerned to appear.

**4.14 REPORT TO RACE COMMITTEE** — As soon as the Race Committee is on the starting line, you are to give your name and sail number to them; and if you leave the race course before the day's racing had ended, you must report to the nearest crash boat or race committee your name and number and that you are going in. Failure to do so could mean disqualification for up to the full season at the discretion of the Laser Fleet officers.

**4.15 LIFE JACKETS** — It is the responsibility of skippers and crews to wear life jackets when conditions warrant whether or not Code Flag "D" (yellow and blue horizontal bars) is displayed, or an orange life jacket in the rigging prior to leaving the dock or prior to the preparatory signal with 2 horns. Skippers and crews shall thereafter wear life jackets throughout the race. Life jackets must be of a type approved by the U.S. Coast Guard or Canadian Department of Transport.

**4.16 SIGN IN** — When Code Flag Y (red with yellow diagonals) is flying from the port spreader of the Rochester Yacht Club flagpole you must report, immediately upon coming ashore, your sail number and name to the bartender. Failure to do so will be disqualification for the day.

**4.17 720° RULE** — The 720° turns penalty as provided in Rule 72.4 and Appendix 3 of the yacht racing rules will apply instead of disqualification for infringement of a rule of Part IV. A yacht which gains relief under this instruction shall report to the RC boat (while it is still on the finish line) the leg on which she did her turns and the number of the other yacht involved.

**4.18 FOLLOW ME** — Hoisting of Code flag L and the firing of three guns means follow the Committee Boat until new signals are given.

## 5. LADIES RACING ASSOCIATION

These instructions will apply in addition to the General Sailing Instructions of Section 1.

**5.1 ENTRY** — Member or spouse of member of the Rochester Yacht Club may race.

**5.2 NOTICES** — Skippers' meetings will be held just prior to leaving the dock for the daytime or evening races. Any changes in these instructions will be given at these meetings.

**5.3 SCHEDULE** — Boats must be ready to leave the basin with the whalers as follows:

Daytime Races . . . 9:30 A.M.

Evening Races . . . 5:30 P.M.

Up to six races may be held for each event.

**5.4 START** — The starting line will be between the staff of the committee boat and the nearest buoy.

**5.5 RESERVED FOR FUTURE USE.**

**5.6 RESERVED FOR FUTURE USE.**

**5.7 SIGNAL** — Signal will be as follows: Warning signal . . . White shape . . . 4 minutes; Preparatory signal . . . Blue shape . . . 2 minutes; Starting signal . . . Red shape . . . Start. When possible, those on the committee boat will provide auditory signals, depending upon resources . . . a gun . . . a whistle . . . and/or . . . a yell, with countdown to start from 20 seconds.

**5.8 RECALLS** — *Individual recalls* . . . will be hailed (i.e. over early). *General recalls* . . . signal will be two guns.

**5.9 COURSE SIGNALS** — The diagram with identifying letters shown indicate types of courses to be sailed. The identifying code flag will be displayed from the committee boat or with the warning signal. I . . . Windward, leeward and windward. M . . . Triangle with start and finish in middle of leg.

**5.10 COURSE CHANGE AFTER START** — The course may be altered or shortened after the start providing the race committee draws attention to the change before an altered leg is begun.

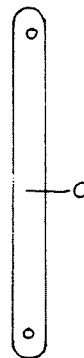

I

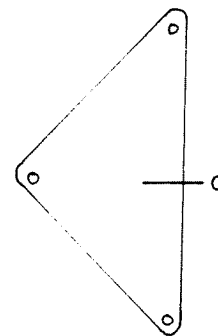

M

5.11 **FINISH** — The finish line will be between the committee boat and the nearest buoy, (see course). In the event of a shortened course the committee boat will be stationed nearest whichever buoy marks the end of the final leg.

5.12 **TIME LIMIT** — A race will be abandoned if no boat has finished within 60 minutes. It may be abandoned earlier at the discretion of the race committee. Any boat(s) not finishing within 25 minutes of the first yacht's finish will be scored as "Did not finish" (DNF).

5.13 **PROTESTS** — A protesting boat must hail the boat being protested, using the word "Protest", and must display a protest flag. In this series, any piece of red material at least 5 inches square, displayed conspicuously on the rigging will satisfy the requirement. Unless the protested boat exonerates herself, the protestor must notify the race committee of her intention to protest as soon as possible after the race.

All protests must be submitted in writing to the race committee within 30 minutes of docking.

5.14 **720° RULE** — The 720° turns penalty as provided in Rule 72.4 and Appendix 3 of the yacht racing rules will apply instead of disqualification, for infringement of a rule of Part IV.

A yacht which gains relief under this instruction shall report to the Committee boat (while it is still on the finish line) the leg on which she did her turns and the number of the other yacht involved.

5.15 **SAFETY** — The safety of each member is the responsibility of the member. LSD's must be worn at all times while racing (a rule). Boats must not leave the vicinity of the whaler without permission from the race committee.

5.16 **SCORING** — Low points wins . . . no averaging.

Place	Points
1st	3/4
2nd	2
3rd	3
4th	4
etc.	and so on

DNF — number of boats which started that race

DNS — number of boats in series up till that race (including competitor to be scored)

DSQ — number of boats in series up till that race + 1

5.16.1 **THROWOUT** there will be one "throw out" race out of every 6 races completed, (i.e. out of 6 to 11 races, the worst 1 race may be thrown out. Out of 12 to 17 races, the worst 2 races may be thrown out).

5.16.2 **TIEBREAKER** if necessary for the award of flags and/or any prizes, ties will be broken using the system described in Appendix 5, section 4. Any tie still remaining will be broken in favor of the boat which scored the most recent first place, or if still remaining, the most recent second, etc.



EDITOR: Patricia Polidor

ASSOCIATE EDITORS: Jerome Lewis  
Suzanne Fischer  
Raymond DelMonte  
Julia Bolton

PHOTOGRAPHY: Taffy McKeon  
William J. Stolze  
Walter Chappelle, Jr.  
John Menihan

COVER DESIGN: David H. Spreng & Associates

PRINTING: The Daily Record Corporation