

YOUR ASSURANCE OF

Quality



Tobin's

FIRST PRIZE



FIRST PRIZE PRODUCTS ARE U. S. GOVERNMENT INSPECTED

Tobin PACKING CO., INC. • 900 MAPLE STREET • ROCHESTER 2, N. Y.

LYRA

1963

**ROCHESTER
YACHT CLUB**

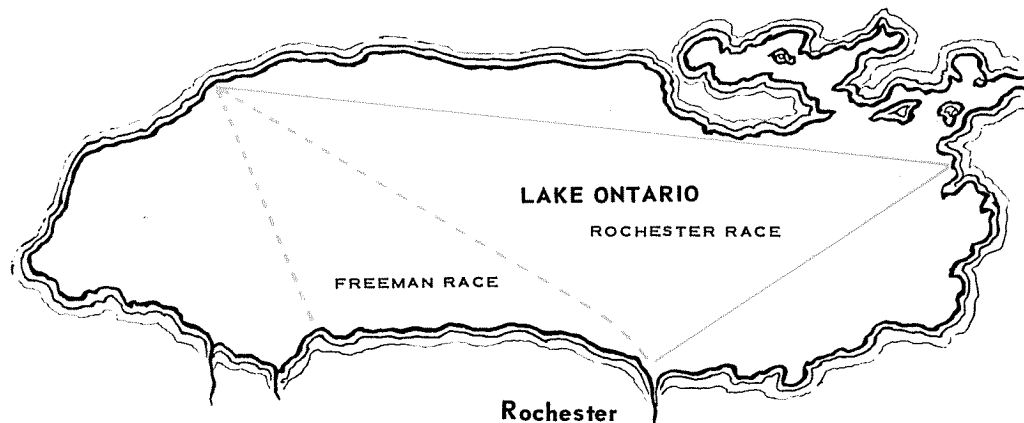

LAKE ONTARIO'S GREATEST WEEK OF RACING

- **FREEMAN CUP
AUGUST 4**
- **L.Y.R.A.
AUGUST 7, 8, 9**
- **ROCHESTER RACE
AUGUST 10**

Welcome

Speaking for all members of the Rochester Yacht Club I want to welcome you to the 1963 LYRA Regatta. Our Regatta committee is looking forward to providing you with a week of racing and social activity which will be remembered for a long time.

It has been some time since our club has been host to the LYRA. This gives us the chance to repay the many favors our members have received from all of you at your club. We have many friends all along Lake Ontario and we welcome this opportunity to have you as our guests.

The sailing plans are terrific. There will be a week full of racing sufficient to satisfy the most ardent sailors. This is our ambition since we are a racing yacht club. I believe that completing the LYRA activities with the start of the Rochester race, as planned this year, puts the finishing touch on a real race week.

Again, we welcome you. We hope you will ask any RYC member for information or help as you need it. We are prepared to give it. Best of luck in your 1963 LYRA Regatta races.

Robert R. Dobbin
Commodore

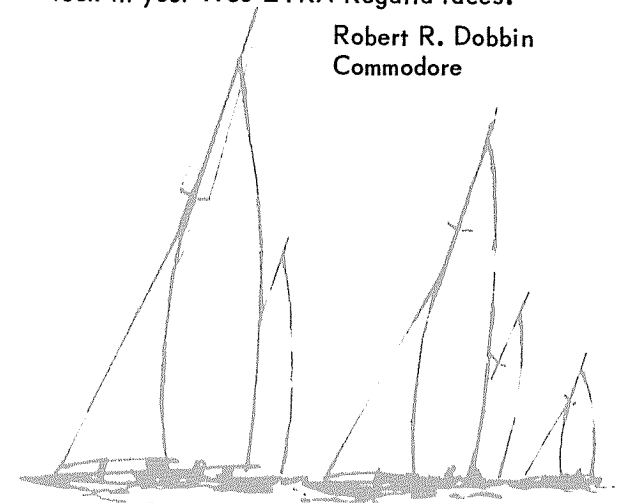
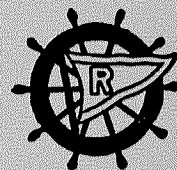

CONTENTS

LYRA COMMITTEE

FREEMAN LONG DISTANCE COMMITTEE

GENERAL INFORMATION – LYRA

FREEMAN STARTING TIMES

REGISTRATION FEES

PREVIOUS FREEMAN WINNERS

COURSE RACING INSTRUCTIONS

KEEL BOATS

CENTERBOARD BOATS

INFORMATION FOR VISITORS TO
ROCHESTER

PREVIOUS REGATTAS

MEMBER CLUBS

PREVIOUS COURSE WINNERS

ENTERTAINMENT LOG

ROCHESTER RACE

SHIPS AND SAILS BY GEORGE CULP

OUR ADVERTISERS

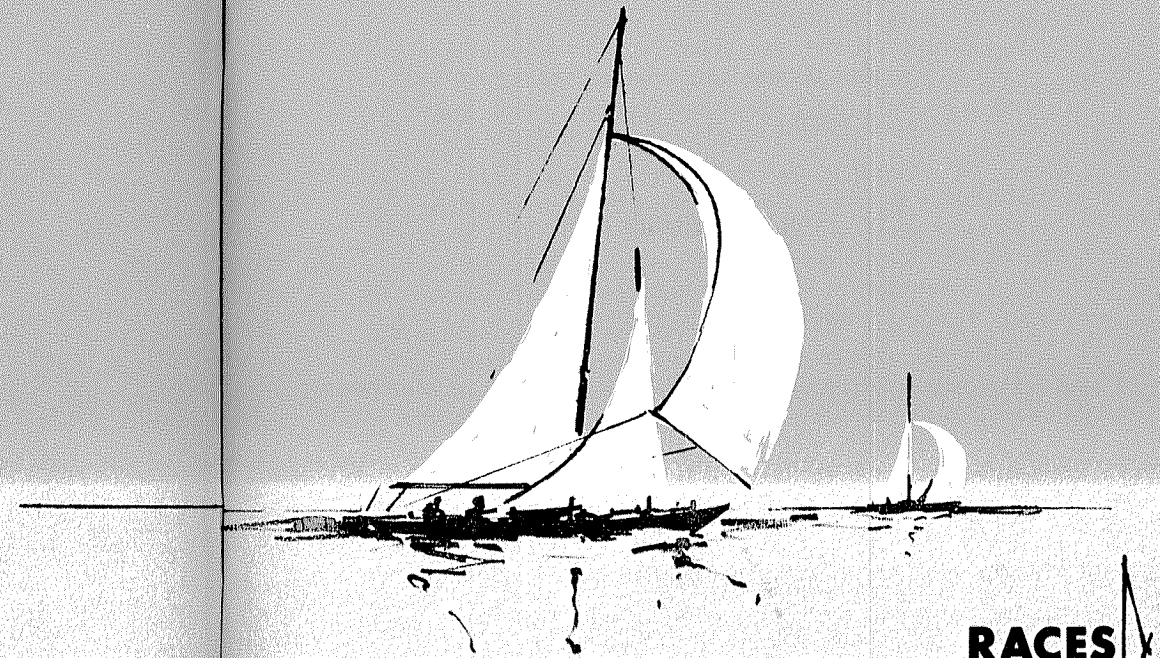

ILLUSTRATIONS BY
RICHARD MURPHY

RACES

1963 EXECUTIVE COMMITTEE

Karl Smither, B.C.C. *Honorary President*
Arnold A. Gorman, Q.C.Y.C. *President*
Newton B. Castle, R.Y.C. *Vice-President*
Fred Brade, R.H.Y.C. *Vice-President*
A. H. Gorsline, R.Y.C. *Secretary-Treasurer*

RACE COMMITTEE

E. G. Sorsoleil, R.C.Y.C. *General Chairman*
George Hurrell, N.Y.C. *Chairman-Center-Boards*
Pat Hurrell, N.Y.C. *Center-boards*
Walter Heussler, B.C.C. *Timer*
Herbert M. Hill, Jr., B.C.C. *Line Caller*
Wesley Farrell, N.Y.C.
Jean Farrell, N.Y.C.
C. Wesly Gamble, C.Y.C. *Prizes and Trophies*
Don McChesney, R.Y.C. *Course boat*
Arn Gorman, R.C.Y.C. - R.C.Y.C.
E. Gorman, R.C.Y.C. - Q.C.Y.C.
A. H. Gorsline, R.Y.C.
M. Patterson, R.C.Y.C.
R. Kemp, R.Y.C.

PROTEST COMMITTEE

Douglas Hooper, B.C.C. *Chairman*

Wm. Garrett, R.C.Y.C.

FREEMAN CUP

LONG DISTANCE RACES

1. These handicap races are open to all yachts owned by Members of Clubs belonging to the L.Y.R.A. and guests.
2. The owner or skipper of each yacht entering the race shall file, before the race, a declaration of the yacht's safety equipment on a form supplied by the L.Y.R.A. The Registrar will supply a list of minimum requirements at the Y.Y.C., as set out in paragraph #16 of these instructions. This list was approved by the Council of the L.Y.R.A. All yachts shall then be inspected by members of the Race Committee at the Y.Y.C. on August 2 and 3, 1963.
3. 1963 N.A.Y.R.U. Rules and 1963 C.C.A. Measurement Rules to apply. Exception: the foremost fixed part of the yacht will be taken as a determining factor that the yacht has started or finished.
4. The starting line for both courses will be about 2½ miles east of the mouth of the Niagara River, about ¼ mile off shore. The Bouy will have a silver revolving top on steel poles and will have orange and white stripes around the base. It is a regular racing mark of the Youngstown Yacht Club. You may check their chart at the Club House for the location.
5. START: will be between the white flag on the committee boat and the above bouy. The bouy will be left to STARBOARD for both starts. The Committee boat will change position between the start of the Race around Toronto and the one direct to Rochester.
6. COURSES: Yachts in Divisions "A" thru "D" shall race from Youngstown to the Eastern gap at Toronto then to Rochester Harbor. Weather permitting the "ELSIE D" a power boat will be on station at Toronto about ¼ mile SOUTH of the WEST Pier of the Eastern Gap and shall be used as a turning mark of

FREEMAN CUP (Continued)

the course and shall be passed on your STARBOARD SIDE. IF WEATHER does not permit a stake boat a white SPAR bouy will be in the same position and will carry a YELLOW L.Y.R.A. FLAG and this spar bouy shall be passed on your STARBOARD side. The course will then be direct to Rochester Harbor. Yachts in Divisions "E thru H" shall race direct to Rochester from Youngstown.

7. FINISH: There will be one finish line for both courses, off the piers at Rochester. There will be a bouy with an L.Y.R.A. Flag on it about ¼ mile due NORTH of the WEST PIER at Rochester. The committee boat, weather permitting will be at Anchor about 200 yards due north of the bouy. You are to leave the bouy to Starboard and the Committee boat to PORT. Should weather not permit a Committee boat you are to leave the bouy to Port and the finish time will be taken by the Committee on the WEST Pier. PLEASE take your own time at the finish so that it may be checked with the Committee after you have finished. IF YOU FINISH AFTER DARK PLEASE SHOW A LIGHT on your sail number for positive identification.
8. The distance for the course from Y.Y.C. to Rochester is 70 nautical miles for the purpose of calculating the handicaps. The distance from Y.Y.C. to R.C.Y.C. to Rochester is 105 nautical miles for the purpose of calculating the handicaps.
9. Long Distance Races will be sailed under 1963 N.A.Y.R.U. rules from before the start until 30 minutes after the start, after which Rules of the Road shall apply. Any yachts sailing without lights in violation of the Rules of the Road will be disqualified.
10. Any yacht not properly displaying her racing numbers on sails will not be recognized. Any yacht using numbers other than those she registered under must

FREEMAN CUP (Continued)

notify the Committee before the start of the race, if possible before the Committee leaves the dock.

11. Any yacht dropping out of the race must notify the Committee at the Rochester Yacht Club to avoid needless searches.
12. No yacht shall use her ship-to-shore phone to better her position.
13. There will be a briefing meeting of skippers or their representatives at the Youngstown Yacht Club on August 3rd at 9 P.M.
14. Protests will be in accordance with the N.A.Y.R.U. Procedure except they must be on an L.Y.R.A. form. Any yacht committing a foul on the starting line shall, at the decision of the Race Committee, have 10 minutes added to its corrected time at the finish.
15. Attention is called to Rule #27 of the N.A.Y.R.U. relative to masthead burgees and pennants.
16. SAFETY REGULATIONS: Acted upon by Council Meeting of November 12, 1960.
 1. Must have adequate manual bilge pump even though they have power pump.
 2. Must have charts and navigation instructions.
 3. Compass that is accurate.
 4. Proper fire extinguisher - in compliance with regulations of their respective governments - Canadian or American.
 5. 6 day or 6 night flares or 12 railway type flares in properly protected water-proof wrapping.
 6. Lead and lead line.
 7. Two (2) suitable anchors with minimum of 150 ft. of rope or chain.
 8. At least one government approved life jacket for each man aboard - two with whistles attached.
 9. Suitable fog horn.
 10. Suitable first aid kit.
 11. One or more suitable life rings near helmsman

FREEMAN CUP (Continued)

- with automatic flare attached.
12. Minimum of 3 good flashlights – one with 3" minimum lens for signalling.
 13. 1 eleven-quart rigid pail for boats up to 40 feet in length.
 14. 2 eleven-quart rigid pails for boats over 40 feet in length.
 15. Log book and customs papers.
 16. Storm canvas or suitable reefing gear.
 17. Must have weighted pole with fluorescent flag attached, handy to helmsman to be used in event of man overboard.
 18. Radar reflector: need not be carried open but is to be used in case of emergency.
 19. Small red flashlight for each member of the crew to be worn on clothing when on deck after sunset. This will show a red glow.

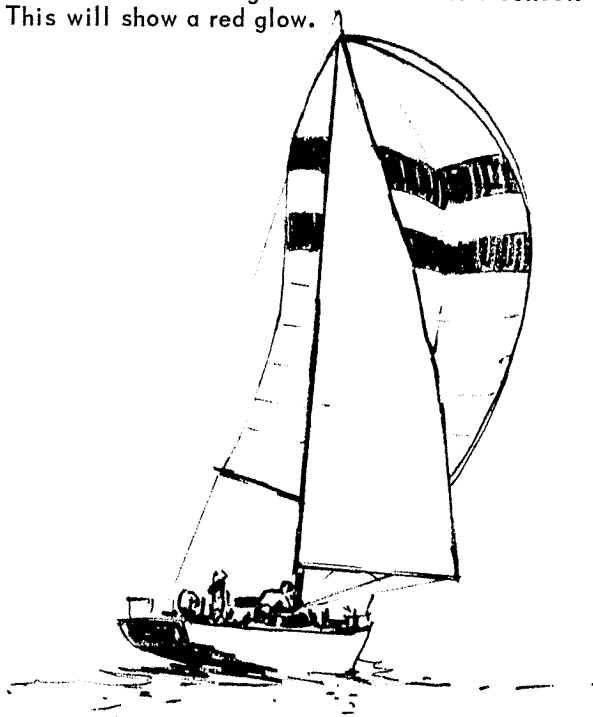

LONG DISTANCE RACES – AUGUST 4th, 1963

Starting times:

Starting Times

YYC to Toronto to Rochester

TIME OF START	NUMERAL PENNANT	CLASS	DIVISION	TROPHY
12:50 P.M.	Code Flg. W	Warning		
12:55 P.M.	Code Flg. P	Preparatory		
1:00 P.M.	Numeral 1	LOR 22.1 and Over	A	Miss Simplicity Cup
1:05 P.M.	Numeral 2	C.C.A. 23.1 to 34.9	B	Charles Freeman Cup
1:10 P.M.	Numeral 3	C.C.A. 35.0 and over	C	Rochester Cup
1:15 P.M.	Numeral 4	8 Meters	D	Y.R.U. Cup

Should there be any "R" Boats they will start with the 8 Meters and be scored as a separate division. The Mabbett Cup would be awarded to the First "R" to finish.

Short or Direct to Rochester Course

1:35 P.M.	Code Flag W	Warning		
1:40 P.M.	Code Flag P	Preparatory		
1:45 P.M.	Numeral Pennant 1	Universal Class	E	Douglas B. Jones Tom Taylor to 1st Tumlaeren
		Knarrs-Dragons-Tumlaerens		
1:50 P.M.	Numeral Pennant 2	L.O.R. 22.0 and under	F	Founders Cup
1:55 P.M.	Numeral Pennant 3	C.C.A. 23.0 and under	G	Louise Freeman Cup
2:00 P.M.	Numeral Pennant 4	6 Metres & 5.5 Metres	H	President's Cup

1st boat to finish – All Classes – Short Course – The Olcott Cup

Flags will be lowered 30 seconds before the hoisting of the next signal. In case of gun failure the flags will be official.

GENERAL INFORMATION

1. REGISTRATION: Skippers on arrival at Youngstown Yacht Club must register themselves and crew at the L.Y.R.A. Office with the Lt. Registrar William Garrett. Skippers having registered at Y.Y.C. will not be required to register at R.Y.C.
2. NO BOAT of any club will be recognized on the starting line of the Long Distance Races leaving from Youngstown, unless the Skipper has registered and completed the proper entry forms and had his boat inspected by The Race Committee. Nor will any boat, including centerboards, be recognized in the three day regatta at Rochester, unless the skipper or his agent has appeared before the registrar at Rochester Yacht Club.
3. All Regatta and Long Distance race entries shall be made through the yacht club of which the competitor is a member and the entry fees shall be paid by the individual to his own yacht club. Such yacht club shall then send one cheque to the Secretary, Mr. A. H. Gorsline, 330 East Lake Road, R.D. #2, Williamson, New York, U.S.A. to cover all the entries from one club. The cheque and entry forms must be in the hands of the Secretary by Tuesday, July 23rd, 1963.
4. To operate the Long Distance Race and three days of the Regatta in an efficient manner, all entries must be compiled, handicaps set up, stencils cut and entry lists multigraphed. Each year, a few skippers complain about paying a double fee for late entry. This fee is compulsory due to the work involved. The entries received by the Secretary for one week after July 23rd may be accepted but only if covered by an entry fee which is double the regular entry fee. The fees of entrants who do not participate in either

the Regatta nor Long Distance Race will be refunded upon request of the yacht club from which the entry was made.

5. Over and above the information set out in paragraph 2, all yachts and centreboard boats must file a registration form before they participate in any race of the 3-day Regatta or the Long Distance race. This registration will be filed by the skipper or by a designated member of his crew at Youngstown for Keel boats in the Long Distance Races. Boats, including centreboard yachts, not in the L.D. race will register immediately upon arrival at R.Y.C., Rochester. Unless a boat is registered with Wm. Garrett it shall not be recognized on the starting line during the 3 days of the Regatta. A form must be completed.
6. CUSTOMS AND IMMIGRATION: Officials will be on hand at Y.Y.C. In order to avoid some of the serious difficulties of former years, please make certain that you contact the officers and secure clearance certificates.
7. Please examine the list of required safety cruising equipment found elsewhere in this program.
NO YACHT SHALL BE RECOGNIZED in the Long Distance race unless the said owner or skipper has filed a Declaration Form of Cruising Equipment with the Registrar at Y.Y.C. You shall then present your yacht for inspection at Y.Y.C. to the Race Committee of the L.Y.R.A.
8. All times referred to in the program are E.D.S.T. Morning gun: 8 a.m., Sunset gun: 8:30 p.m. colours. The time to be taken from gun at Headquarters.
9. Supplementary instructions shall be posted daily on the bulletin board at R.Y.C. The Race Committee shall meet at Headquarters at 6:00 p.m. daily for the consideration of any business that may come before it. Special meetings of the council may be called

during the Regatta by way of bulletin board announcement. The Race Committee requires all yachts to be at the starting line on time and that each class keep clear of the Senior class in the area of the starting line, otherwise they may be disqualified for interference.

10. The instructions are clear. The Race Committee will not answer questions while on the starting line. Please co-operate with the Race Committee and stay away from the starting line while they try to set up a good line that you desire and appreciate.
11. The Registrar shall have authority, with consent of the Race Committee, to accept late entries but only at double the entry fee. Any skipper laying claim to having paid his entry fee to his own Yacht Club but not on record with the Treasurer or the Registrar, may race by paying a double entry fee and having his club give satisfactory evidence that the fee was paid on time, in which case the double fee paid shall be rebated to the said club. (July 23rd is closing date - see that your club sends entries on time.

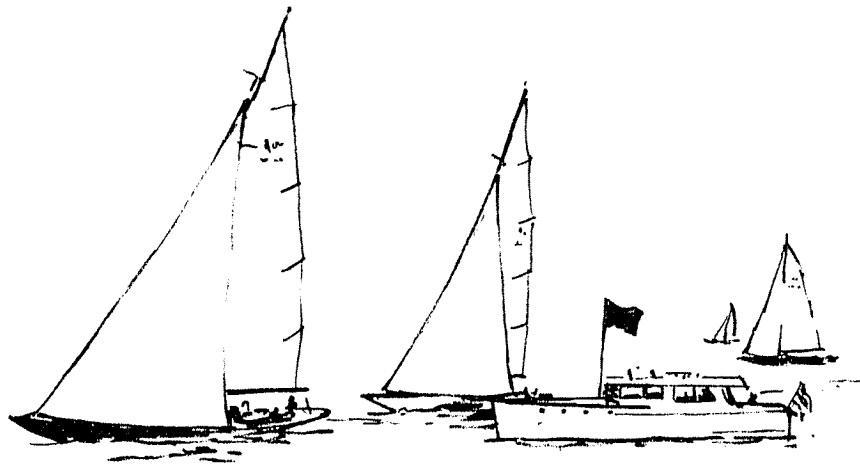

REGISTRATION FEES

Cover either or both Regatta or Long Distance Races

DIV. I - C.C.A. - 35.0 and Over	\$15.00
DIV. II - 8 Metres	15.00
DIV. III - 6 Metres	12.00
DIV. IV - 5.5 Metres	10.00
DIV. V - L.O.R. 20.1 and Over	10.00
DIV. VI - C.C.A. 23.0 to 34.9	11.00
DIV. VII - Stars	6.00
DIV. VIII - Dragons	9.00
DIV. IX - Seafarers and Tumlarens	9.00
DIV. X - Knarrs	6.00
DIV. XI - Rainbows and Crusaders	6.00
DIV. XII - C.C.A. Under 23.0.	9.00
DIV. XIII - L.O.R. 20.0 and Under	9.00
DIV. XIV - International Folkboats	9.00
DIV. XV - Great Lakes Folkboats	9.00
DIV. XVI - Rhodes 19.	6.00
DIV. XVII - Additional Class.	7.00
Centreboards All Classes.	5.00
Centreboards Recognized Jr. Clubs.	3.00

Entries must reach the Secretary of L.Y.R.A. by July 23, 1963 in order to avoid a penalty of double the above fee. Entry must be made thru your club with the check sent to A. H. Gorsline, Secretary L.Y.R.A., 330 East Lake Road, Williamson, New York.

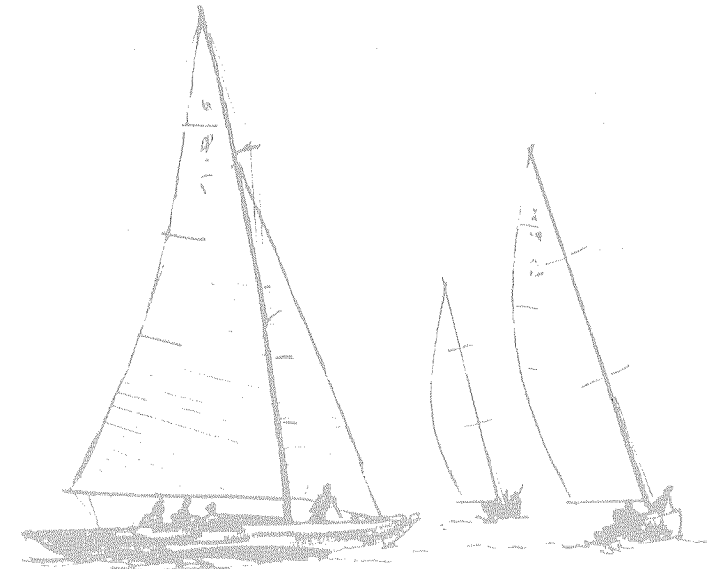

PREVIOUS LONG DISTANCE RACE WINNERS

* Trophy not in competition or not raced for

CHAS.
FREEMAN CUP

'21	Haswell
'22	Cara Mia
'23	Stranger
'24	Cara Mia
'25	Rogue
'26	Stranger
'27	Kathea II
'28	Diana
'29	Safara
'30	Safara
'31	Yolanda
'32	Cayuga
'33	Kathea II
'34	Cayuga
'35	Conewago
'36	Norseman
'37	Cayuga
'38	Patricia
'39	White Wings
'40	Vision
'41	Bangalore
'45	Tramp Royal
'46	Tramp Royal
'47	White Wings
'48	Chance
'49	Lorelei
'50	Aquilla
'51	Venture III
'52	Jack
'53	Sashay
'54	Buzzy II
'55	Sashay
'56	Venture II
'57	Sashay
'58	Pompadour
'59	White Wings
'60	Inishfree
'61	Inishfree
'62	Inishfree

DOUGLAS B.
JONES TROPHY

'49	Can-Can
'50	Jill
'51	Norseman
'52	Shadow
'53	Stork
'54	Flying Cloud
'55	Kathea II
'56	Shadow
'57	Petunia Seed
'58	Galebird
'59	Whisper
'60	Talikai
'61	Madame
'62	Conquest

LOUISE
FREEMAN CUP

'37	Ethel C.
'38	Four Winds
'39	Tramp Royal
'40	Winlassie
'41	Estrella
'45	Nimbus
'46	Fo'castle
'47	Quest
'48	Daphne
'49	Jack
'50	Venture III
'51	Shadow
'52	Sashay
'53	Aquilla
'54	Sashay
'55	Johan
'56	White Squall
'57	Venture II
'58	Norseman
'59	Norseman
'60	Norseman
'61	Norseman
'62	Norseman

MABBETT CUP

'29	Moutte
'30	Safara
'31	Kathea II
'32	Kathea II
'33	Kathea II
'34	Kathea II
'35	Kathea II
'36	Cotton Blossom
'37	Tyconna
'38	Kathea II
'39	Shadow
'40	Kathea II
'41	Shadow
'45	Shadow
'46	Shadow
'47	Shadow
'48	Shadow
'49	Diana
'50	Shadow
'51	Shadow
'52	Shadow
'53	Shadow
'54	Shadow
'55	Kathea II
'56	Shadow
'57	Shadow
'58	Shadow
'59	Diana
'60	Shadow
'61	Galatea
'62	Dawning

PRESIDENT'S
TROPHY

'36	Aphrodite
'37	Mist
'38	Mist
'39	Mist
'40	Mist
'41	Djinn
'45	Jill
'46	Circe
'47	Circe
'48	Circe
'49	Erne
'50	Jill
'51	*
'52	Stork
'53	Stork
'54	Buzzy II
'55	Johan
'56	*
'57	Johan
'58	*
'57	Johan
'58	*
'57	Johan
'58	*
'60	Invasion
'61	Zephyr
'62	Cutty Shark

FOUNDER'S CUP

'38	Blue Moon
'39	White Wings
'40	*
'41	Vitesse II
'45	Nimbus
'46	Xanadu
'47	Alondra
'48	Seneca II
'49	Fo'castle
'50	Sashay
'51	Evangeline
'52	Si Si
'53	Ivanhoe
'54	Dutch Treat
'55	Rascal
'56	Ivanhoe
'57	Madame
'58	Madame
'59	Dawning
'60	Pompadour
'61	Madame
'62	Fairwind

Y.R.U. CUP

'51	Venture III
'52	Mitena
'53	Ivanhoe
'54	Venture II
'55	Sashay
'56	Venture III

'57	El Margaret
'58	Pompadour
'59	Ivanhoe
'60	Inishfree
'61	Inishfree
'62	Jinx

ROCHESTER
CUP

'40	Kathea II
'41	Cayuga
'45	Shadow
'46	Invader
'47	Vision
'48	Shadow
'49	Norseman
'50	Jack
'51	Invader
'52	Norseman
'53	Apache
'54	Bibis
'55	Shadow
'56	Shadow
'57	Invader
'58	Invader II
'59	Venture II
'60	Thisbe
'61	Thisbe
'62	Conawaga

TOM TAYLOR
TROPHY

'47	Silhouette
'48	Valhalla
'49	Valhalla
'50	Valhalla
'51	*
'52	Silhouette
'53	Valhalla
'54	Valhalla
'55	*
'56	Valhalla
'57	Valhalla
'58	*
'59	Valhalla
'60	Vanir
'61	Valhalla
'62	Conquest

OLCOTT CUP

'55	Sashay
'56	Happy Talk
'57	El Margaret
'58	Pompadour
'59	Ivanhoe
'60	Inishfree
'61	Inishfree
'62	Vanir

LYRA INFORMATION

COURSE RACING KEEL BOATS

COURSE RACING INSTRUCTIONS:

KEEL YACHTS

August 7, 8 and 9, 1963

Rochester Yacht Club

(Courses will be set each day from a point west of the River.)

1. The number of the course to be used will be posted on a side of the Committee Boat. The Committee, with a wish to provide the best racing, will make every effort to start the races with a beat to weather. Continuous off-shore winds may necessitate a reaching start.
2. Open to all Keel Boat Classes belonging to Member Clubs of L.Y.R.A. and guests.
3. Number of Races. ALL DIVISIONS: 3 Races - Weather permitting.
4. RULES: Current N.A.Y.R.U. 1962 C.C.A. Measurement Rules.
5. PROTEST: Shall be made in accordance with N.A.Y.R.U. Rules on a form to be secured from the Race Committee and must be filed within two (2) hours after the protesting boat has finished the race. Protesting yachts shall carry white or red flag in rigging and notify judges of intent. If judge's boat is not notified, at the finishing line, the protest may not stand. The Protestor shall make certain that the protested boat is informed of intent.
PROTESTS SHALL BE HEARD: As soon as conveniently possible after both Judges' boats have returned to the Rochester Yacht Club. Protesting boats should make absolutely certain that all skippers involved have been told of the intent.
Failure of either party to attend such meeting, shall not hold up the Protest or the decision of the Race Committee.
6. Other signals to be used by Judge's boat:
WHITE FLAG: Denoting Judge's boat - when starting

line established.

CODE FLAG (Red): leave buoys to port.

CODE FLAG (Green): leave buoys to starboard.

CODE FLAG "S": Short Course Signal means when displayed: - 2 Guns

(a) near or at the finish, "Finish race with this round at the prescribed finish line". The Race Committee may elect to stop a race at any mark of the course.

(b) elsewhere: "Finish between the nearby mark and the Committee boat".

CODE FLAG "AP": Postponement Signal, means "All races not started are postponed until later in the day; 2 guns - the warning signal will be made thirty seconds after this signal is lowered".

CODE FLAG "N": Cancellation Signal, means "All races, including those in progress are abandoned or cancelled".

If any classes have started the Judges may attempt to go and notify yachts started. FIRST REPEATER FLAG: Blue Triangle pennant with large blue field and smaller yellow triangle inset means when 2 guns are fired and this first repeater flag hoisted that too many boats in the division starting made a premature start and impossible to notify so many.

The class will start 10 minutes after original starting time. A five minute preparatory will be fired. This will advance all unstarted classes ten minutes.

7. Any yacht starting late for its division shall report to Committee Boat giving its name and number, division and scheduled starting time.

8. STRICT OBSERVANCE WILL BE MAINTAINED BY RACE COMMITTEE AND YACHTS WILL BE DISQUALIFIED FOR BEING IN STARTING AREA BEFORE THEIR FIVE MINUTE GUN.

During the last three years, a few disqualified boats have been disturbed. Make certain that you are not

one. Please stay away from the Judges' Boat while every effort is being made to set the starting line you desire while the LYRA Flag is flying. Wait until White Flag is hoisted.

9. YACHT COURSES: The Yacht Courses will be selected in the Lake west of the piers and will be set each day prior to the start and will be a triangle of 9 miles with 3 miles per leg. This shall be twice around, weather and conditions permitting but at the absolute discretion of the Race Committee.

The Small Triangle for Divisions 7 to 17 will be around a triangle of 6 miles superimposed on the Large Triangle and common starting mark with 2 miles per leg. This shall be twice around, weather and conditions permitting but at the absolute discretion of the Race Committee.

See Diagram in program.

The HOME mark for both triangles will be a bamboo pole with RED FLAG. Finish between the buoy and committee boat in a direction from the last mark of the course.

The flags on the 9 mile triangle will be RED. The flags on the bouys for the 6 mile triangle will be Black and Gold.

10. Finish Line: See Diagram in program.

11. Attention is directed to rule of the N.A.Y.R. wherein masthead burgess and pennants are not to be flown while racing. Failure to observe this rule will result in disqualification. Rule 27. 18-2.

12. Any yacht using sail numbers, other than the ones she registered with on her entry blank, must notify the Race Committee, prior to the start of the race . . . if possible before the Race Committee leaves the dock at R.Y.C.

13. No boat will be recognized on the starting line, unless the owner or a designated member of the crew has appeared before the Lt. Registrar, Wm. Garrett,

L.Y.R.A. KEEL BOATS - 1963
 TRIANGULAR RACING COURSES -
 NUMBERS AND BEARINGS

at R.C.Y.C. and completed the provided registration form. Regardless of the entry made by Your Club and sent in, Skippers MUST also file a Registration Form at Rochester Yacht Club before participating in any race, unless they were in the L.D. Races.

14. All contestants should watch the notice board at the Rochester Yacht Club for change of times or regrouping of classes. The Judges' Boat will not answer questions as the instructions are clear.
15. All C.C.A. and L.O.R. Boats must carry a flag on the leech of the mainsail or on the permanent backstay as follows:
- | | |
|-----------------------|------------------|
| C.C.A. 35.0 and over | NO FLAG |
| C.C.A. 23.0 to 23.9 | Red Square |
| C.C.A. under 22.9 | Green Square |
| L.O.R. 20.1 and over | Yellow Square |
| L.O.R. 20.0 and under | Dark Blue Square |
- Flag should be at least 8" x 8"

16. STARTING TIMES. Pick up starting times and signals at Information Booth.

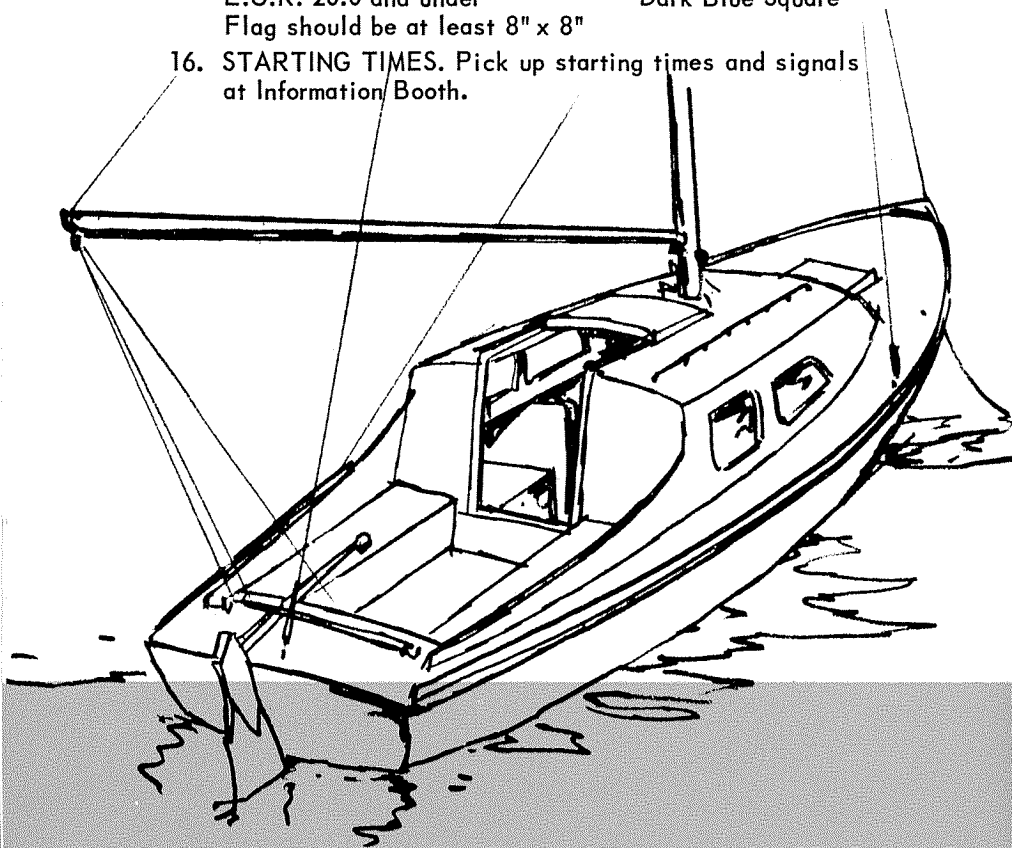

Course No.	COL. I	3rd leg-P COL. II	2nd leg-P COL. III	Course No.
1	10	130	250	1
2	20	140	260	2
3	30	150	270	3
4	40	160	280	4
5	50	170	290	5
6	60	180	300	6
7	70	190	310	7
8	80	200	320	8
9	90	210	330	9
10	100	220	340	10
11	110	230	350	11
12	120	240	360	12
13	130	250	10	13
14	140	260	20	14
15	150	270	30	15
16	160	280	40	16
17	170	290	50	17
18	180	300	60	18
19	190	310	70	19
20	200	320	80	20
21	210	330	90	21
22	220	340	100	22
23	230	350	110	23
24	240	360	120	24
25	250	10	130	25
26	260	20	140	26
27	270	30	150	27
28	280	40	160	28
29	290	50	170	29
30	300	60	180	30
31	310	70	190	31
32	320	80	200	32
33	330	90	210	33
34	340	100	220	34
35	350	110	230	35
36	360	120	240	36

Examples - Course No. 8

IF BUOYS TO STARBOARD

- 1st LEG - 80 deg.
 2nd LEG - 200 deg.
 3rd LEG - 320 deg.

IF BUOYS TO PORT

- 1st LEG - 80 deg.
 2nd LEG - 320 deg.
 3rd LEG - 200 deg.

TROPHIES
COURSE RACING TROPHIES

THE MOTT MEMORIAL TROPHY	- Knarr
THE GOODERHAM CUP	- 8 Meter
THE CASTLE CUP	- 6 Meter
THE MONTGOMERY CUP	- Dragon
THE LAKE ONTARIO CUP	- C.C.A. 35 and Over
THE BALDWIN CUP	- 23.0 and Under
THE SODUS BAY CUP	- C.C.A. 34.9 to 23.1
THE NICHOLS CUP	- L.O.R. 20.0 and Over
THE COMMODORE WORLD TROPHY	- Tumblaren
THE JOHN LABATT TROPHY	- 5.5
THE BOULEVARD CUP	- Rainbow-Crusader



LYRA INFORMATION (Continued)

CENTER BOARD COURSES

August 7, 8 and 9, 1963

Rochester Yacht Club

1. Open to all centreboard yachts belonging to member Clubs of the L.Y.R.A., and guests. A separate start will be given to all classes of three or more boats. Numeral pennants will be used to signify each class.
2. There will be a course laid each day - East of the East pier. The bouys will have Red flags on them. The legs of the triangle will be $1\frac{1}{4}$ miles each. All classes but the Rhodes Bantams and Sailfish and Sunfish will go twice around the Triangle.
3. The course number will be signaled from the committee boat by showing it on a black-board. Your program has the course numbers in it. Number of races: All Divisions: 3 races, weather permitting.
4. RULES: Current N.A.Y.R.U., except the foremost fixed part of a yacht will determine when the yacht has started or finished.
5. PROTESTS: Shall be made in accordance with N.A.Y.R.U. rules on a form to be secured from the Race Committee and must be filed within two (2) hours after the protesting yacht has finished the race. The Protest will be heard, as soon as conveniently possible, after the Judges' Boats have returned to R.Y.C. Protesting skippers must make certain the protested skippers are well aware of the intent. The skipper of the protesting boat, after crossing the finish line, shall return and notify the Judges of this intent or the protest may not be entertained. Failure of either party to attend such a meeting, shall not hold up the protest or decision of the Protest Committee.
6. SIGNALS:
L.Y.R.A. Pennant will identify Committee Boat until starting line is established.
PLEASE STAND OFF UNTIL LINE IS SET UP.

CENTER BOARD COURSES (Continued)

✓ *White Flag*: Starting Line established.

✓ *Green Flag*: All buoys to Starboard.

✓ *Red Flag*: All buoys to Port.

✓ *Code Flag "S"*: Shortened course signal (2 guns)

When displayed:

(a) near end at finish all classes finish race with this round at prescribed finish line.

(b) elsewhere, all classes finish between the nearby mark and Committee Boat.

(c) when displayed over a class signal, as in (A) and (B) above, means that the above signal applies to the designated class only.

✓ *Code Flag "AP"*: Postponement signal (2 guns) means: "All races not started are postponed until later in the day. The warning signal will be made 30 seconds after this signal is lowered."

All times will be advanced the amount of the postponement. Do not go far from the Committee Boat.

Code Flag "N": Cancellation signal (2 guns) means all races, including those in progress, are cancelled or abandoned. The judges shall attempt to notify the classes started.

✓ *First Repeater Flag*: When hoisted and (2 guns) are fired immediately after the start of any class, it means that the class is recalled but will be re-started in ten minutes. This advances the starting times of all classes yet to start by ten minutes. (This could be caused by too many boats starting prematurely for the Judges to attempt to call them back).

Code Flag "F": Finish Signal – Committee boat is on station at the finish line.

✓ *Code Flag "M"*: Should a mark drift away or sink, a patrol boat will be used as a substitute and fly code flag "M".

Code Flag "L": Life Jackets must be worn; any skipper or crew failing to do so, shall be disqualified.

7. Any yacht starting late for its division shall report to the Committee Boat giving its name and number, division and scheduled starting time.

8. STRICT OBSERVANCE WILL BE MAINTAINED BY THE RACE COMMITTEE AND YACHTS WILL BE DISQUALIFIED FOR BEING IN THE STARTING AREA BEFORE THEIR FIVE MINUTE GUN.

9. COURSE: The race will be triangular sailed twice around, unless otherwise specified by the Race Committee. The finish may be taken at any mark of the course if decided upon by the Committee.

10. STARTING LINE: Most important – shall *only* be between the white flag on the Judges' Boat and the buoy carrying code flag "M". The regular turning mark of the triangle, which is a buoy with (Red Flag), will not be recognized as any part of the starting line. Boats completing first round of the triangle shall ignore this starting buoy with code flag "M" and round the regular mark of the triangle. As soon as all Divisions are started, this buoy with code flag "M" shall be removed.

11. Attention is directed to rule wherein masthead burgees and pennants are not to be flown while racing. Failure to observe this rule will result in disqualification.

12. Any yacht using sail numbers other than those she registered with her entry blank must notify the Race Committee prior to the start of the race.

NO BOAT WILL BE RECOGNIZED unless the skipper or a designated member of the crew has appeared before the Lt. Registrar, Wm. Garrett, at R.Y.C. and completed the prescribed registration form. Regardless of the entry form your Club sent in, skippers must also file a registration form in the L.Y.R.A. office at R.Y.C. before racing.

NAYRU →
me "O"
or
"A" over "A"

changed to

code flag "D".

CENTER BOARD COURSES (Continued)

STARTING TIMES and CLASS SIGNALS

TIME	Flag Or Pennant	Class Start
11:20	W	Warning
11:25	P	Preparatory
11:30	1	JOLLY BOATS
11:35	2	Thistles
11:40	3	14' Dinghies
11:45	4	Lightnings
11:50	5	Rhodes Bantams
11:55	6	Sailfish and Sunfish start together - finish as two classes

NOTE: Each signal will be lowered 30 seconds before the hoisting of the next succeeding signal. A gun will be fired with the hoisting of the visible signal. In case of misfire the signal will be official. All skippers should watch the L.Y.R.A. notice board at R.Y.C. for change of time or classes.

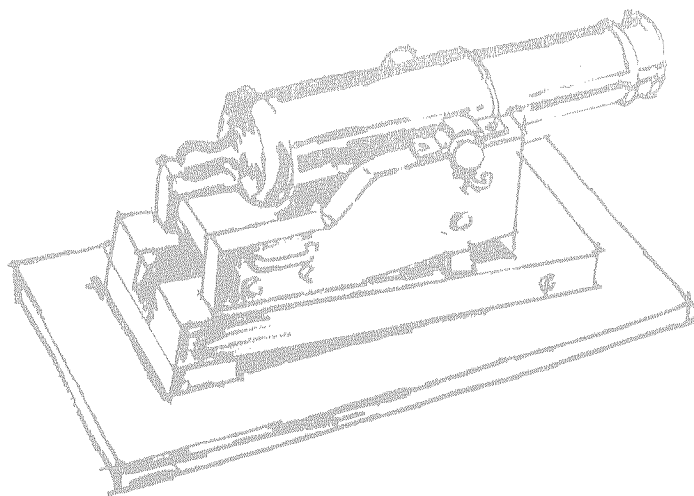

ONSHORE WIND

RED FLAG AND ROUNDING BUOY FOR BOATS DOING MORE THAN ONCE AROUND

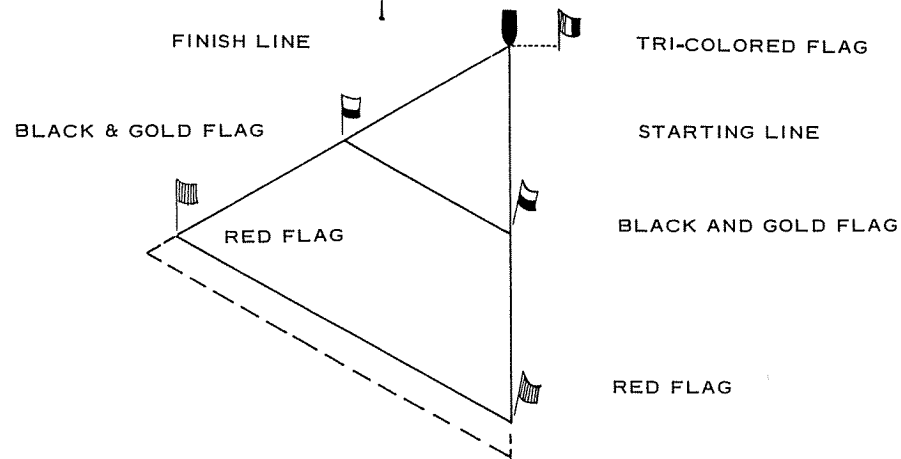

OFFSHORE WIND

NOTE: WHEN STARTING IN THE LAKE ON ONE LEG THE APEX OF LARGE & SMALL TRIANGLES WILL BE BLACK AND GOLD.

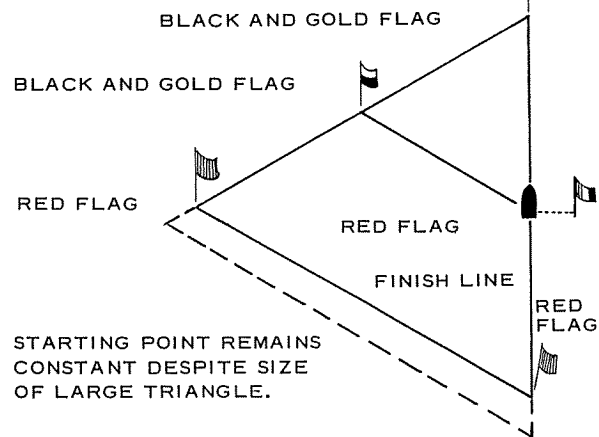

STARTING POINT REMAINS CONSTANT DESPITE SIZE OF LARGE TRIANGLE.

NOTE: ON LARGE TRIANGLE GOLD CUP THE ENTIRE LEG IS REPEATED REGARDLESS OF STARTING LINE LOCATION.

NOTE: SHORT COURSE 2 MI. LEGS
LONG COURSE 3 MI. LEGS

NOTE: IDENTIFICATION OF AN OFFSHORE START CAN BE MADE BY NOTING THE TRI-COLORED FLAG IS NOT OFF THE PIER.

COMMITTEE BOAT FLYING RED FLAG

TRI-COLORED FLAG

STARTING LINE

NOTE: ON LARGE TRIANGLE GOLD CUP THE ENTIRE LEG IS REPEATED REGARDLESS OF STARTING LINE LOCATION.

INFORMATION FOR VISITING YACHTS

The Flag Officer and members of the Rochester Yacht Club will do everything in their power to insure that your visit to the Club is enjoyed.

REGISTRATION – Skippers are responsible for registering all crew members and boats at the L.Y.R.A. Registration Office.

All competitors are reminded that registration must be completed before you can take part in any Regatta event.

MOORING – Moorings will be available for everyone and will be assigned by a member of the Mooring Committee upon your arrival at the Rochester Yacht Club. A member of the Launching Committee will be available at the Information Booth to assist you to the proper launching area.

A crane will be available for keel-boats requiring launching on Tuesday afternoon, August 6th from 2:00 to 5:00 P.M. and Friday afternoon, August 9th from 3:00 to 6:00 P.M. Enclosed trailer storage will be available through the courtesy of Triangle Marine.

The Marine Railway and services of the Rochester Yacht Club will be available to all participants.

Triangle Marine, adjacent to the Club, will also be available for any necessary services.

SUPPLIES – A representative from White City Grocery will be available at the Information tent from 8:30 A.M. to 9:30 A.M. to take orders for your grocery needs. Deliveries will be made the same day between the hours of 4:30–5:30 P.M. Additional orders may be placed between 4:30–5:30 P.M. for delivery the following morning.

SPECTATOR BOATS – Guests will be welcome on Spectator boats which will be available at no charge. Spectators should provide their own food and refreshments. Information may be obtained at the Information Booth.

Towels and soap may be picked up at the Information Booth.

MEALS – Three meals will be served daily at the Rochester Yacht Club. A box lunch will be available Wednesday, August 7th through Friday, August 9th. Orders must be placed by 6:00 P.M. of preceding day.

Laundry service will be available. Information may be obtained at the Information tent.

HOUSING – A limited number of bachelor bunks will be available on a first come – first served basis at a small charge. Information may be obtained at the Information tent.

SOME OF ROCHESTER'S BETTER HOTELS AND MOTELS

- | | |
|---|---|
| Downtowner Motor Inn (240 rooms)
155 Broad St. E.
Rochester 4, N.Y.
LO 2-5480 from \$9.85 | Powers Hotel (300 rooms)
34 Main St. W.
Rochester 14, N.Y.
LO 2-6400 from \$6.00 |
| Manger Hotel (500 rooms)
26 Clinton Ave. S.
Rochester 4, N.Y.
HA 6-7800 from \$6.75 | Rochester Travelodge (106 rooms)
390 South Ave.
Rochester 20, N.Y.
BA 5-8000 from \$8.00 |
| Midtown Tower Hotel (70 rooms)
14th Floor Midtown Plaza
Rochester 4, N.Y.
BA 5-9000 from \$10.50 | Sheraton Hotel (300 rooms)
111 East Ave.
Rochester 4, N.Y.
BA 5-8400 from \$6.85 |
| Mohawk Motor Inn (80 rooms)
55 Troup St.
Rochester 8, N.Y.
LO 2-9190 from \$8.00 | Treadway Inn (146 rooms)
384 East Ave.
Rochester, N.Y.
BA 5-2060 from \$9.85 |

PREVIOUS L.Y.R.A. REGATTAS

- 1919 - Port to Port - Assembled at Hamilton, August 2 -
To Toronto, August 4 - To Olcott, August 5 -
To Charlotte, N.Y., August 6 - Regatta, August 7
To Cobourg, Ont., August 8 . Regatta, August 9
- 1920 - Cobourg, Ont. August 2, 3 and 4
- 1921 - Kingston, Ont. August 3, 4 and 5
- 1922 - Prinyer's Cove, Ont. July 10, 11 and 12
- 1923 - Belleville, Ont. August 1, 2 and 3
- 1924 - Sodus Bay, N.Y. August 6, 7 and 8
- 1925 - Belleville, Ont. August 5, 6 and 7
- 1926 - Henderson Harbor, N.Y. August 4, 5 and 6
- 1927 - Kingston, Ont. August 4, 5 and 6
- 1928 - Oswego, N.Y. August 1, 2 and 3
- 1929 - Toronto, Ont. August 27, 28 and 29
- 1930 - Hamilton, Ont. August 19, 20 and 21
- 1931 - Henderson Harbor, N.Y. July 28, 29 and 30
- 1932 - Cobourg, Ont. August 9, 10 and 11
- 1933 - Fair Haven, N.Y. August 7, 8, 9 and 10
- 1934 - Toronto, Ont. August 28, 29 and 30
- 1935 - Kingston, Ont. July 23, 24, 25 and 26
- 1936 - Youngstown, N.Y. August 4, 5 and 6
- 1937 - Rochester, N.Y. July 29, 30 and 31
- 1938 - Toronto, Ont. July 27, 28 and 29
- 1939 - Hamilton, Ont. July 27, 28 and 29
- 1940 - Big Sodus, N.Y. July 25, 26 and 27
- 1941 - Youngstown, N.Y. July 24, 25 and 26
- 1945 - Hamilton, Ont. August 1, 2 and 3
- 1946 - Kingston, Ont. July 31, August 1 and 2
- 1947 - Toronto, Ont. July 28, 29 and 30
- 1948 - Clayton, N.Y. July 22, 23 and 24
- 1949 - Toronto, Ont. August 3, 4 and 5
- 1950 - Chaumont, N.Y. July 26, 27 and 28
- 1951 - Chaumont, N.Y. July 17, 18 and 19
- 1952 - Toronto, Ont. August 6, 7 and 8
- 1953 - Rochester, N.Y. July 29, 30 and 31
- 1954 - Toronto, Ont. August 4, 5 and 6
- 1955 - Hamilton, Ont. August 1, 2 and 3
- 1956 - Toronto, Ont. June 30, July 1 and 2
- 1957 - Rochester, N.Y. July 20, 21 and 22
- 1958 - Port Dalhousie, Ont. August 2, 3 and 4
- 1959 - Sodus Point, N.Y. July 22, 23 and 24
- 1960 - Toronto, Ont. July 30, 31 and August 1
- 1961 - Belleville, Ont. August 4, 5 and 6
- 1962 - Toronto, Ont. August 4, 5 and 6
- 1963 - Rochester, N.Y. August 7, 8 and 9

MEMBER CLUBS OF THE L.Y.R.A.

- Bay of Quinte Yacht Club Belleville, Ont.
- Buffalo Canoe Club Point Abino, Ont.
- Bronte Yacht Club Burlington, Ont.
- Clayton Yacht Club Clayton, N.Y.
- Crescent Yacht Club. Chaumont, N.Y.
- Dalhousie Yacht Club Port Dalhousie, Ont.
- Henderson Harbor Yacht Club. . Henderson Harbor, N.Y.
- Island Yacht Club. Wilson, N.Y.
- Island Yacht Club of Toronto Toronto, Ont.
- National Yacht Club. Toronto, Ont.
- Olcott Yacht Club Olcott, N.Y.
- Port Credit Yacht Club Port Credit, Ont.
- Queen City Yacht Club Toronto, Ont.
- Rochester Yacht Club Rochester, N.Y.
- Royal Canadian Yacht Club. Toronto, Ont.
- Royal Hamilton Yacht Club. Hamilton, Ont.
- Sodus Bay Yacht Club Sodus Point, N.Y.
- Youngstown Yacht Club Youngstown, N.Y.

ASSOCIATE MEMBER CLUBS OF THE L.Y.R.A.

- Alexandra Yacht Club Toronto, Ont.
- Ashbridges Bay Yacht Club. Toronto, Ont.
- Buffalo Yacht Club Buffalo, N.Y.
- Canandaigua Yacht Club Canandaigua, N.Y.
- Fair Haven Yacht Club Fair Haven, N.Y.
- Fanshawe Yacht Club London, Ont.
- Genesee Yacht Club. Rochester, N.Y.
- Kingston Yacht Club Kingston, Ont.
- La Salle Yacht Club Niagara Falls, N.Y.
- Newport Yacht Club Rochester, N.Y.
- Niagara Sailing Club. North Tonawanda, N.Y.
- Oakville Yacht Squadron Oakville, Ont.
- Oshawa Yacht Club Oshawa, Ont.
- Presquile Yacht Club . . Presquile Point, Brighton, Ont.
- St. Catharines Boat Club Inc. . . . St. Catharines, Ont.
- T.D.C.Y.R.A. Toronto, Ont.
- Royal St. Lawrence Yacht Club Dorval, Que.
- Skaneateles Country Club Skaneateles, N.Y.
- The Boulevard Club Toronto, Ont.
- Toronto Sailing and Canoe Club Toronto, Ont.
- Canadian 5.5 Meter Ass'n. Toronto, Ont.
- Canadian Y-Flyer Racing Ass'n. Dorval, Que.

Member of North American Yacht Racing Union •
Member of Canadian Yachting Association

PREVIOUS COURSE RACE TROPHY WINNERS

LIPTON CUP

- '25. Kathea I
- '26. Eleanor

LIPTON CUP

- '25. Kathea I
- '26. Eleanor
- '27. Kathea II
- '28. Shadow
- '29. Safara
- '30. Spray
- '31. Bobcat
- '32. Shadow
- '33. Safara
- '34. Safara
- '35. Cotton Blossom
- '36. Kathea II
- '37. Cotton Blossom
- '38. Shadow
- '39. Shodow
- '40. Kathea
- '41. Shadow
- '45. Shadow
- '46. Shadow
- '47. Shadow
- '48. Shadow
- '49. Diana
- '50. Shadow
- '51. Diana
- '52. Shadow
- '53. Shadow
- '54. Shadow
- '55. Shadow
- '56. Shadow
- '57. Shadow
- '58. Vivia II
- '59. *
- '60. *
- '61. *
- '62. *

LAKE ONTARIO TROPHY

- '41. Vitesse II
- '45. *
- '46. Alondra
- '47. White Wings
- '48. Evangeline
- '49. Venture III
- '50. *
- '51. Ida
- '52. Venture III
- '53. Ivanhoe
- '54. Tramp Royal
- '55. *

- '56. Ivanhoe
- '57. El Margaret
- '58. El Margaret
- '59. Diana
- '60. White Wings
- '61. Galetea III
- '62. FairWind

GOODERHAM CUP

- '30. Vision
- '31. Quest
- '32. Conewago
- '33. Conewago
- '34. Quest
- '35. Conewago
- '36. Vision
- '37. Norseman
- '38. Invader II
- '39. Conewago
- '40. Bangalore
- '41.

- '39. Conewago
- '40. Bangalore
- '41. Invader II
- '45. Bangalore
- '46. Quest
- '47. Quest
- '48. Norseman
- '49. Quest
- '50. Norseman
- '51. Invader
- '52. Quest
- '53. Vision
- '54. Thisbie
- '55. Invader
- '56. Norseman
- '57. Norseman
- '58. Norseman
- '59. Norseman
- '60. Norseman
- '61. Norseman
- '61. Norseman
- '62. Venture

NICHOLS CUP

- '32. Grayling
- '33. Four Winds
- '34. Four Winds
- '35. Four Winds
- '36. Cock Robin
- '37. Grayling
- '38. Four Winds
- '39. Cock Robin

- '40. Hellcat
- '41. Scrapper II
- '45. Scrapper II
- '46. Tramp Royal
- '47. Xanadu
- '48. Xanadu
- '49. Xanadu
- '50. Flying Mist
- '51. *
- '52. Laurel
- '53. Si Si
- '54. Whistler
- '55. Si Si
- '56. Aquilla
- '57. *
- '58. *
- '59. Diana
- '60. Sashay
- '61. Whisper II
- '62. Diana

CASTLE CUP

- '53. Buzzy II
- '54. Buzzy II
- '55. Buzzy II
- '56. Buzzy II
- '57. Buzzy II
- '58. Stork
- '59. Buzzy I
- '60. Bibis
- '61. Goose
- '62. Goose

MOTT TROPHY

- '36. Nonchalant
- '37. Patricia
- '38. Patricia
- '39. Nutmeg II
- '40. Eleanor E.
- '41. Spindrift
- '45. Seneca
- '46. Alera
- '47. Alera
- '48. Alera
- '49. Alera
- '50. Ida III
- '51. *
- '52. Si Si
- '53. *
- '54. *
- '55. *
- '56. Jill
- '57. *
- '58. Sno Goose
- '59. *
- '60. Whisper

- '61. Whisper
- '62. Lynstrale

MONTGOMERY TROPHY

- '47. Grenadier
- '48. Grenadier
- '49. *
- '50. Shadow
- '51. Merendol
- '52. *
- '53. *
- '54. Flying Cloud
- '55. Bajads
- '56. Happy Talk
- '57. Rebb III
- '58. Happy Talk
- '59. Ballerini
- '60. Gailbird
- '61. Snapdragon
- '62. Lynx

SKANEATELES TROPHY

- '47. Rampage
- '48. Rampage
- '49. Rampage
- '50. Rhoda
- '51. Rhoda
- '52. Rampage
- '53. Thermis 5 M's
- '54. Thermis 5 M's
- '55. Thermis 5 M's
- '56. Atom
- '57. Rampage
- '58. Just Us
- '59. *
- '60. Serendipity
- '61. Cosmos
- '62. Flareii

SODUS BAY CUP

- '47. Daphne
- '48. Damoiselle
- '49. Tramp Royal
- '50. Sashay
- '51. Si Si
- '52. Sashay
- '53. Skaneateles III
- '54. Ivanhoe
- '55. *
- '56. Sashay
- '57. Si Si
- '58. Bins

- '60. Onyx
- '61. Si Si
- '62. Sashay

WORLD TROPHY

- '36. Nirie II
- '37. Colleen
- '38. Spindrift
- '39. Sygnet
- '40. Blue Moon
- '41. Iduna
- '45. Valhalla
- '46. Valhalla
- '47. Valhalla
- '48. Valhalla
- '49. Passing Cloud
- '50. Valhalla
- '51. *
- '52. Kyra
- '53. Valhalla
- '54. Conquest
- '55. Gaylord
- '56. Gaylord

- '57. Gaylord
- '58. Valhalla
- '59. *
- '60. Valhalla
- '61. Valhalla
- '62. Valhalla

BALDWIN CUP

- '36. Blue Moon
- '37. Amorita
- '38. Vitesse II.
- '39. Azura
- '40. Winlassie
- '41. Caprice.
- '45. Tramp Royal
- '46. Revelry
- '47. Skookum
- '48. Latonka IV
- '49. Stormalong II
- '50. Setay
- '51. Chance
- '52. *
- '53. White Squall
- '54. Ivanhoe

- '55. *
- '56. Si Si
- '57. Sashay
- '58. Si Si
- '59. Sashay
- '60. Galatea
- '61. Talakadi
- '62. Pivot I

JOHN LABATT TROPHY

- '58. Windekind
- '59. *
- '60. Svalen
- '61. Jill
- '62. Windigo

BOULEVARD CUP

- '58. Djinn
- '59. *
- '60. Vagabond
- '61. *
- '62. Bilmar

- L.O.R. MISS SIMPLICITY
- '58. Seneca
 - '59. Diana
 - '60. Wendigo
 - '61. Jill
 - '62. Whisper

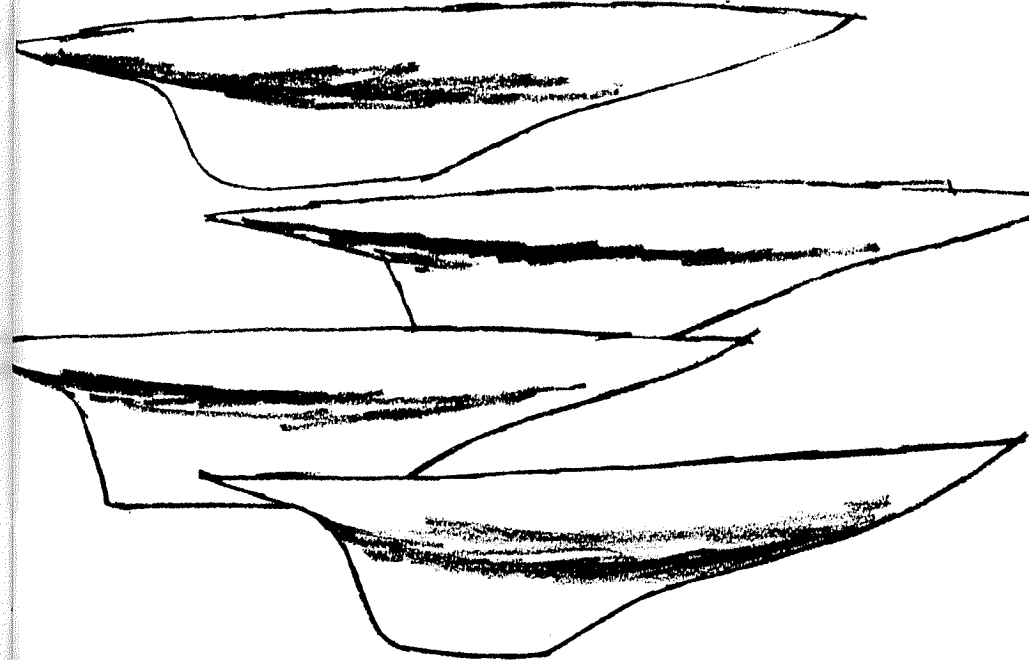

ENTERTAINMENT LOG

Monday

Buffet Dinner from 6:30 til 8:30.

Tuesday

12:30 Bus to Finger Lakes Race Track for Rochester Yacht Club Day. \$5.00 covers transportation both ways. Entrance to the Club House and Lunch. Buffet Dinner from 6:30 til 8:30 followed by a get-acquainted party with Yachting Movies.

Wednesday

Beachcomber Party with Buffet 6:30 til 8:30. Calypso music and limbo contest.

Thursday

Cook your own steak on charcoal 6:30 til 8:30. Music by Max McCarthy's Tailgate Ramblers.

Friday

Cocktails and Banquet with award of Prizes. Dancing 9 til 2.

ROCHESTER RACE INSTRUCTIONS

PURPOSE:

The purpose of the Rochester Race is to encourage the design, building and racing of seaworthy yachts suitable for off-shore cruising and racing. Through such races it is hoped that boats sailing off-shore, will be prepared in both equipment and ability to meet any conditions which might be encountered on the lakes.

ELIGIBILITY:

The Race is open to all cruising boats of a recognized Y.C., whose C.C.A. rating is not less than 20.5 ft., whose fore and aft overhangs do not exceed 1/3 of the length overall, whose ballast displacement ratio is less than 46%, whose beam length ratio is no less than 1 to 5. All yachts must be of a seaworthy type strongly built and rigged, properly ballasted with enclosed cabins, watertight self-draining cockpits.

EQUIPMENT:

The following equipment is required and will be subject to inspection prior to the race. All measurements are supplementary to those of the USCG or Canada Shipping Act, and the LYRA long distance races.

1. Suitable life lines including permanent stanchions properly fastened.
2. One life preserver with whistle and light attached for each crew member.
3. One approved life ring or horseshoe type life saving device with water light and dye marker attached.
4. An approved life raft or dinghy, equipped with floatation tanks and life lines capable of supporting entire crew.
5. Suitable reefing tackle.
6. Taff Rail Log.
7. Wire cutters capable of cutting running and standing rigging.

All yachts must be equipped with permanently installed engines with shaft and propeller, and with sufficient fuel in permanently fixed tanks to permit them to operate under

ROCHESTER RACE INSTRUCTIONS

power for a minimum of 5 hours. The final determination of eligibility of yachts remains with the Rochester Race Committee.

MEASUREMENT:

All yachts must submit a measurement certificate in accordance with the 1963 C.C.A. rule with their application.

All yachts will be inspected for equipment prior to noon August 10th. Toronto area boats may be inspected by Peter Davidson, Tel. 278-8763.

Additional conditions of the race will appear in the race instructions.

The start will be at 3:00 P.M. E.D.T. between a buoy 1/4 of a mile off and in line with the west pier and the committee boat - to be designated at the skippers meeting. All boats will start in one class. The warning gun will be at 2:50 P.M. and indicated by the raising of Code Flag W at 2:54:30 the flag will be lowered. At 2:55 the preparatory gun will be fired indicated by the raising of Code Flag P and the numeral 3. At 2:59:30 the flags will be lowered and at 3:00 the starting gun will be fired and Code P and numeral 3 will be raised again.

COURSE:

From Rochester northeast to Story Island, (which may be rounded in either direction) thence westerly to Toronto.

RIGHT OF WAY:

The Racing Rules of the N.A.Y.R.U. will apply from the preparatory gun until 30 minutes after the start of the Race. Thereafter, rules of the road at sea will apply.

RUNNING LIGHTS:

Appropriate running lights shall be displayed between sunset and sunrise. Violation of this rule will mean disqualification.

RADIO TELEPHONES:

No restrictions will be placed on the use of Radio Telephones.

ROCHESTER RACE INSTRUCTIONS

ABANDONMENT OF RACE:

Any yacht dropping out of the Race is requested to call the Rochester Yacht Club collect Fillmore 2-5511 promptly so that no needless search will be started for her.

AUXILIARY MOTORS AND AUTOMATIC STEERING DEVICES shall not be used.

FINISH:

The Finish shall be between the end of the east pier at the east gap of Toronto Harbor entrance and the committee boat. In the event that weather makes it impossible for the committee boat to be on station take your own time as you pass it between the east and west pier entering the Eastern gap to Toronto.

A Coast Guard Cutter will patrol the race and lend assistance in case of emergency.

CERTIFICATE:

All entries must be accompanied with a 1963 CCA Certificate and check for \$25.00 made payable to RYC.

BANQUET – Monday night RCYC.

RADIO – WBBF 950 KC will broadcast urgent messages and special weather forecast.

PROVISIONS – Food may be ordered from the White City Grocery Representative at the info tent. Orders must be made Thursday afternoon August 8. Delivery will be made at 9:30 A.M., Saturday, August 10.



*George Culp – June 29, 1873
June 18, 1962*

Actor, Musician, Composer,
Author, Businessman, Yachts-
man, and Poet – George Culp
was a man of many talents.

He served as Commodore of
the Rochester Yacht Club in
1908. He devoted over 20 years
to R.Y.C. and many years to
LYRA as a member of the Race
Committee.

He has left us a legacy of
poems that capture the poignacy
of sailing that all of us sense,
but so few of us can adequately
express.

For this we are grateful.
We thank you, George Culp.

SHIPS and SAILS

by George Culp

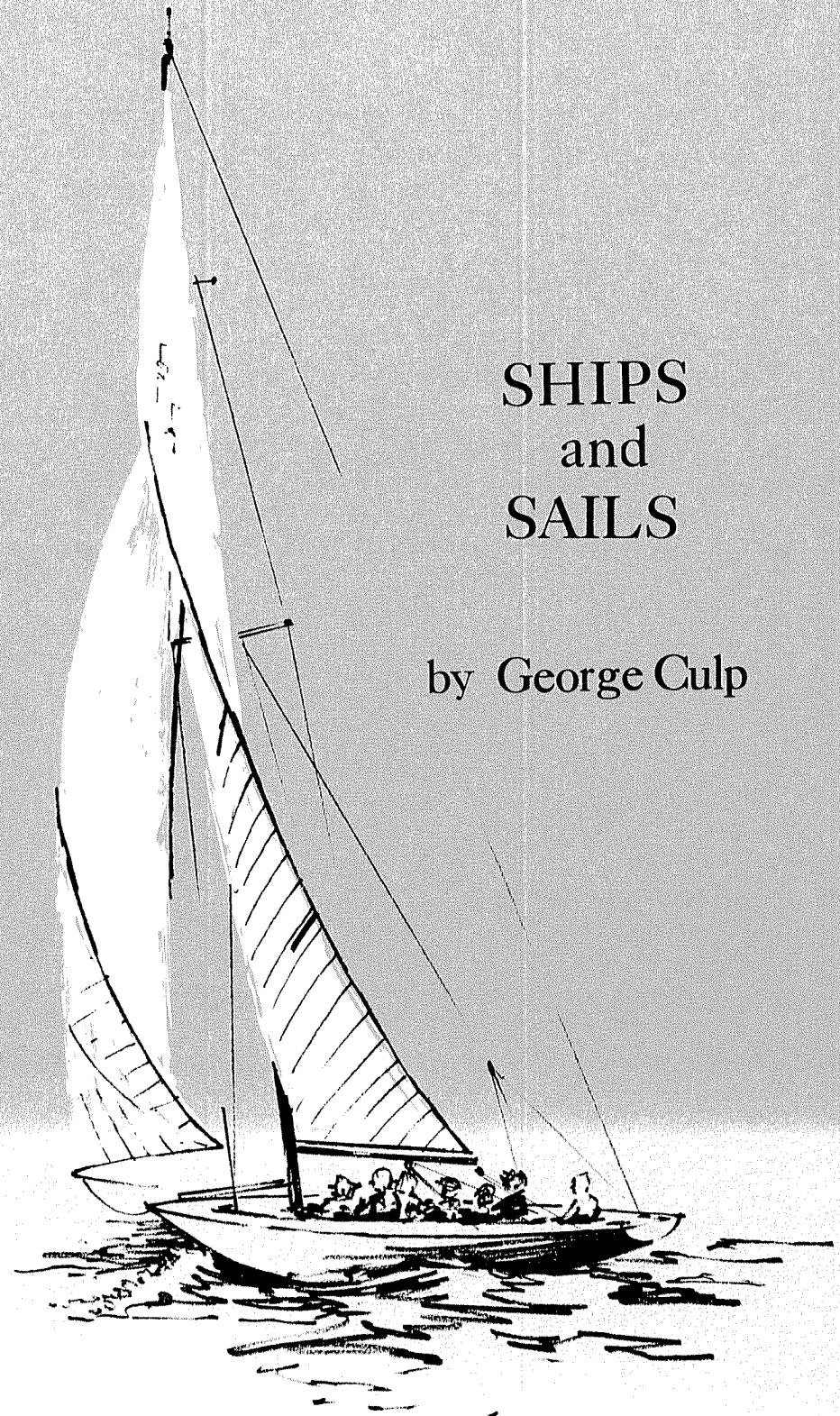

TO PETE

Good old Pete! Thank God he won.
Declining years will be great fun.
I see him now in lee of locker,
In the sun – and in a rocker,
Telling how the great WHITE SQUALL
Beat 'em one and beat 'em all.
"Twas back in Nineteen Fifty Three,
"The wind was fair and sheets were free ----"
Then follows details we may skip
For we all know his battleship,
And how his first-prize classy crew
Worked every hour to bring it through.

All Hail to Pete, his Crew his Boat –
And bless his heart – the tough old goat.

George Culp August Twenty Six

ODE TO ODENBACH

As firm as concrete, hard as rock,
Is Johnny Circe Odenbach.
By tucks and nips
The Six he skips
Stays out in front by half a block.

His Circe circles every buoy
With latitude that must annoy
And get the goats
Of trailing boats
That sense no victory or joy.

To Johnny and his loyal crew
All praise and glory that is due;
And when they've taken
Home the bacon
They will have some fat to chew.

When Circe's lines are through the chock
And cleated to the damp old dock,
If lose or win
He'll merely grin.
We owed this Ode to Odenbach.

George Culp 1947

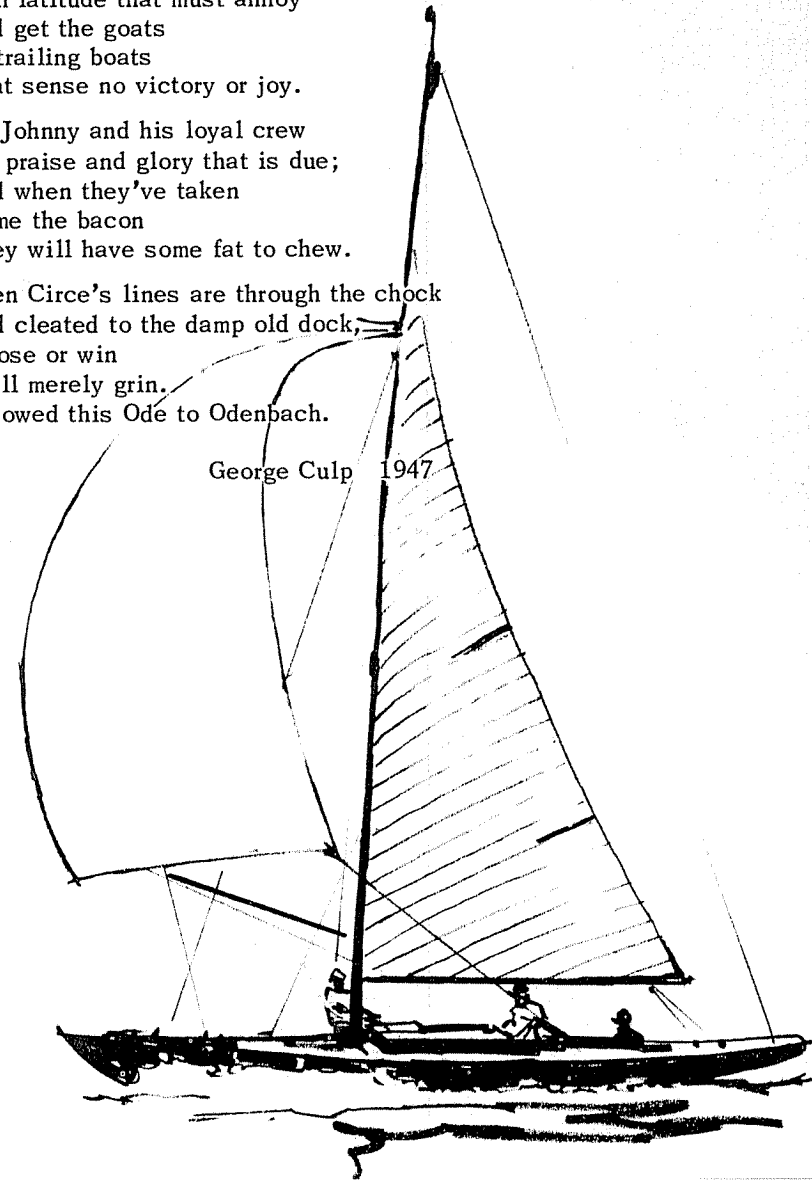

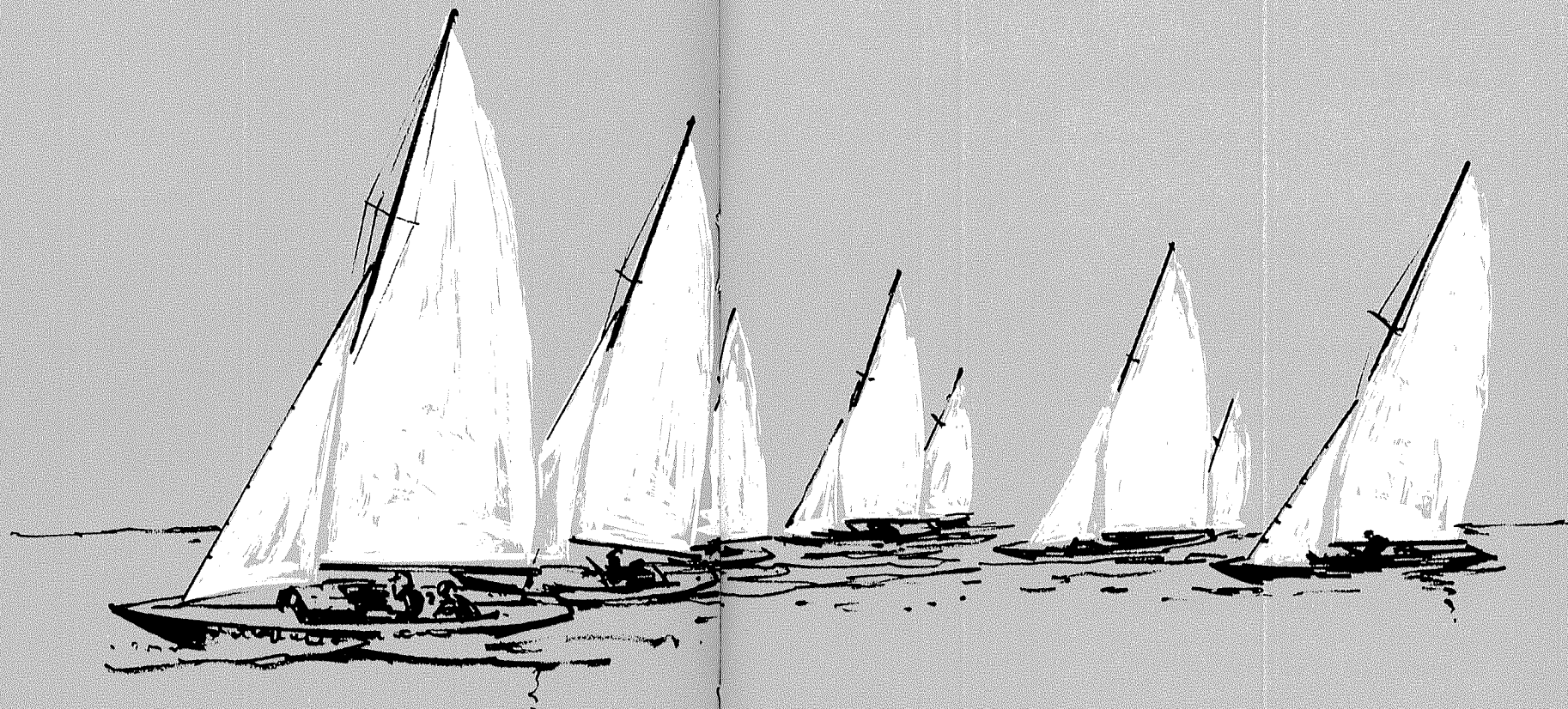

CROSSING THE BAR

(After Bliss Carmen's version.)

Sunset and sailing Star,
And a race won for me;
And all the skippers waiting at the bar,
When I come in from sea.

Not such a gang as losing makes them sore,
Dour with defeat;
But sailors who will ask to sail some more,
And hard to beat.

Midnight and mellow mind,
And then the coming dawn;
And may there be no parting shot unkind,
When I am gone.

For though within this group I have a place,
My status as a tar,
I never more shall sail another race,
When they have crossed the bar.

George Culp

GOOD STAR

Give me a boat I can sail,
A boat that I don't have to bail,
A boat that has gottom a watertight bottom,
That won't open up in a gale.

Give me a boat I can race,
A boat that can set 'em the pace,
A boat that can run, reach and beat from the gun,
A boat that wins cups by the case.

Give me a boat I can drive,
A boat that a gale makes alive,
A boat that can take it, slam bang and shake it,
A boat that will always survive.

Give me a boat with a flexible spar,
A mains'l with draught, and a jib sim-i-lar,
With a bottom that's smoother 'n harder than
And I'll say to sailormen: You cannot pass.

To sum it all up I'm a wind-jammin' tar,
A-τ otin' 'h tootin' for just a good Star.

George Culp

SAW A ROBIN ON THE WING

Saw a robin on the wing
and other birds that chirp and sing;
Sun is warming up the slugs,
the angleworms and all the bugs,
swells the pussy-willow bud,
draws the crocus through the mud.
Time to don the dungarees,
plant the spinach, beans and peas,
mix a batch of D D T,
get the mower running free.
(Ought to have two pairs of hands
to do the things the time demands —)
What's that, Junior? Want some string?
Fish are biting? Funny thing,
I've got nothing much to do,
Guess I'll go a-fishing too!

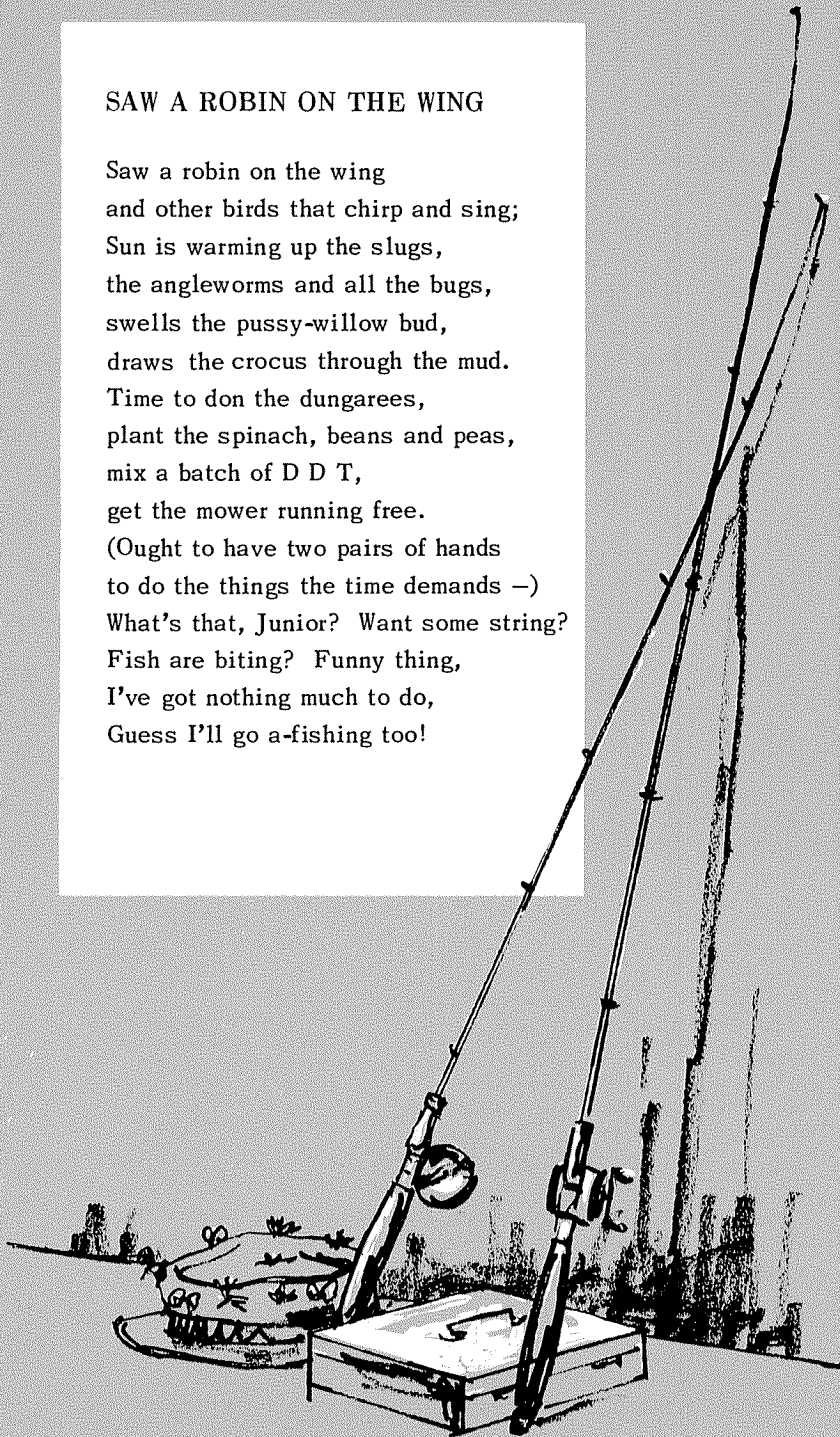

ETERNAL FEMININE

Women used to sit at home and cook and knit and darn
While menfolks went a-yachting- but therein lies a yarn.

Time was when yachtsmen sailed their yachts
Without the aid of women,
With men and men alone aboard
For hoistin' sails and trimmin'.
Men cooked and ate the meals alone
And washed the dirty dishes,
And when they liked shed pants and shirt
For swimmin' bare like fishes.

The yachtsmen's world was strictly male
When racing and when cruising,
'Twas for men only, tellin' tales
At anchor and at boozing.
Free and easy, no restrictions,
Life with no restraint,
Free from gross and petty troubles,
Free from all complaint.

So it was until the women
Bit by bit did learn
More or less about the menfolks
Fun, and did they yearn!
Hearin' more and then some more
They did a job at learnin'.
The more they learned the more they yearned
And nearly died of yearnin'.

When women yearn enough and long
They free an inner craft
That otherwise is dormant and it
Makes 'em sort of daft.
And none but daffy women would
Presume to dare to stick
Their lovin' little noses
Into man's own baliwick.

But stick they did. They poked, they pushed,
Then pouted, wailed and cried,
And when the women get that way
They will not be denied.
Since Adam, back in Eden,
Lovely Eves man cannot shake,
He learned what applesauce will do
Through Satan's slimy snake.

So man, poor man, gave up the ship.
Eternal feminine
Reduced the pristine power and pomp
And status masculine.
But after all is said and done
Men like it like as not,
For men are funny creatures —
So are women, on a yacht.

George Culp

SAILOR'S WIFE

The sailor's wife can't sit at home
and let her sailing hubby roam
at will upon his private yacht.
She has to face it,; she cannot.

In fact before he leaves the dock
she works at least once round the clock
to furnish countless odds 'n' ends.
And to the task she gladly bends
for she'll be free to come and go
at will while he's away. YOU know!

He has to have a roast of ham
a can of pickles and some jam
a pot of good old Boston beans
(she mustn't fail to patch his jeans)
a batch of cookies, home-made bread,
(a pillow for his balding head)
a hundred items on the list
of which some several will be missed.

When he had gone she came and went
on nothing less than pleasure bent.
But in her mind she knew there lurked
some crisis in which she'd be jerked.

It happened. Telephone from Dad.
"Can't get home. Weather's bad."
"Come and get us with the car."
(Only eighty miles. No far!)

And so she cancels all her dates
and drives thru counties, towns and states
to pick up hubby and his crew.
And tells them all a Thing or Two!

She got him home and into bed
with nasty cough and cold in head.
Why did he limp? He had no skin
from knee to ankle on a shin.

'Tis sad for wives of sailing yachters.
Yours quite truly,

AARON WATERS.

George Culp 1956

DINGHY SKIPPER

The dinghy skipper for a crewman
Takes into his craft a woman
Teaches her to do the hiking
How and when all to his liking
Shows her all the tricks of sailing
Up and down the wind and bailing
Setting spinnakers and trimming
Expert plain and fancy skimming.

So it is till end of season
When the two for some queer reason
Wonder why they were so stupid
Not to feel the darts of Cupid
Then the winter finds them dating
Going steady till the mating
All result of sailing spooning
Followed by the honeymooning

Love will come to dinghy yachters
Yours quite surely.



LOCKER PARTY

They were whoopin' it up in the locker, on a Sunday Afternoon.
The rum was flowing freely, and the gang was getting in tune.
Some sixteen Six-metre sailors, plus skippers that numbered four,
Made twenty that started the party – but soon there were twenty more.

A Series had just been finished; 'twas the end of a drawn-out fight.
And every one of the racing tars was happy and getting tight.
The winning skipper and gallant crew were toasted and cheered and praised,
And the party proceeded to gather strength and speed in the hell it raised.

The locker was none too spacious with the sails and the gear it housed,
The fellows were packed like mackerel – like mackerel, salty and soused.
As rum went in the sweat came out; it oozed from every pore.
And every pore was pouring like it never poured before.

As time went on this human mass was coated as with grease.
If any friction had been there by now it sure did cease.
As torsos touched they slipped and slid and slithered full 'n' by.
It was no trick at all to get another drink when dry.

The source of all this rummy cheer was at the western end,
Where on an empty crate the host did sit and mix and blend.
He'd sip a bit himself and with his guests got more than mellow.
What once were light rum highballs got so heavy you would bellow.

The salty songs and stories now were mixed with beefy burps,
As pent-up alcoholic gas blew off in snorts and chirps.
But every tar could stand altho he wobbled when he walked.
And tongues began to thicken so they'd slobber when they talked.

The celebration now was prime when suddenly some Salt –
I think it was the one that's known to every one as Walt –
Went out the door, dove off the dock in trousers, shoes and cocks,
And swam around the basin seeing fifty seven docks.

The locker now was empty, all except the host had gone.
And he sat on that empty crate and slept till almost dawn.
His name? Your guess is good as mine – with that you'll have to wrassle.
It is a fact that, like man's house, his locker is his castle.

George Culp 1947

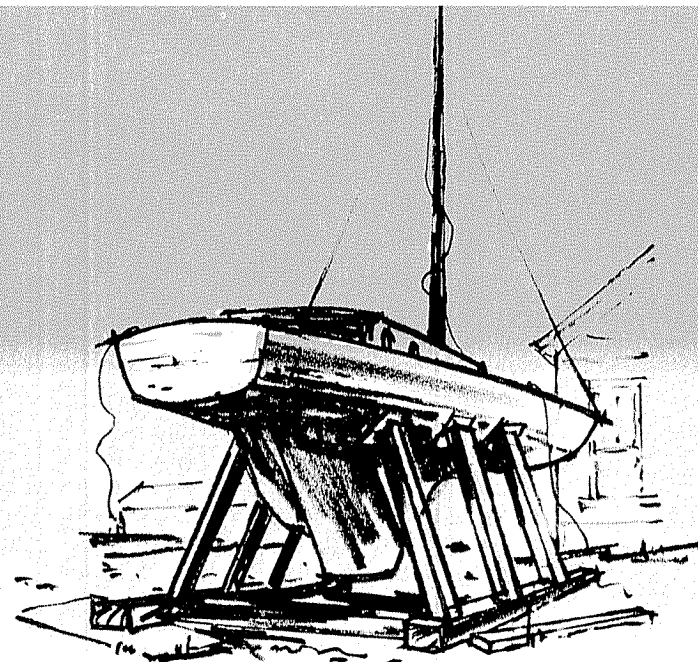

LAMENT

You've been a darn good boat Ol' Girl –
You've served me well and true.
I hate to see you fall apart –
But that's what all boats do.

When stem and plank and rib and keel
Succumb to Old Dry Rot
There's nothing much more man may do
For his beloved yacht.

I've cut and fitted planks and frames
Til you were quite like new
From stem to gudgeon-keel to rail –
But what I've done won't do.

Your ribs no longer hold their curves,
Your planks are warped and sprung,
Your keel, so flabby, soft and weak,
No longer holds the bung.

You're gone Ol' Dear, Ol' Pal, Ol' Girl –
Below the waves you'll slip
When I can get the courage up
To shove you – Good Ol' Ship . . .

George Culp 1948

THE UNPAID HAND

I DOFF MY CAP to the unsung crew
Who do the things they're told to do;
That hardy, loyal, faithful band —
The toiling throng — the Unpaid Hand.

The Unpaid Hand in his dungarees,
Rough and ready and aimin' to please,
A-pullin' the sheets and cleatin' em fast
So the *Sassy Sal* won't finish last.

The Unpaid hand who boils and burns
On a windless day, when the buoy-turns
Are hell to handle and hard to make
In a sizzling sun on a listless lake.

The Unpaid Hand in a gale o' wind —
Soaked to the bone — his knuckles skinned —
Settin' the spinnaker — takin' it in —
Hoistin' the genoa — sweatin' like sin —
Hikin' to weather to trim the boat —
Bailin' like hell to keep afloat —
Haulin' the backstays — trimmin' the main —
Over'n over'n over again.

And when the races have all been run
And the boat he crewed on's the boat that won,
And the lucky skipper is steppin' up
To get his flags and the Silver Cup

* * * * *

Back in the corner — feelin' grand —
With a nice little bun — sits the Unpaid Hand.

George Culp 1941



THE ROAD FROM TYRO TO SKIPPER

He's often made to stand a watch
in dark and dirty weather,
including rain and wind and fog,
quite often all together;
At times he has to splice and serve
wire cable and manila,
and rig the proper halliards
for to signal the flotilla.

He's called upon to lay aloft
to clear a fouled condition,
and set a flying fisherman
to save a lead position.
He sometimes has to shoot the sun,
to hand, to reef, to steer, too;
and plot a course to keep him off
the shoals — and never near to.

He'll learn in time what polish does
to brass that's bound to tarnish,
and what sand-paper means proceeding
putty, paint and varnish;
He'll learn the dock-mop, swab and sponge,
the chamois and the bucket,
and how to get the water from the
bilge when pump won't suck it.

He'll be the one to crack the ice
and serve when they are drinkin' —
and then he'll have to steer the ship
in case they all get stinkin'.
and one thing more — He'll have to cook
and do the dirty dishes,
and empty all the garbage
overside to feed the fishes.

He'll study things celestial,
the big and little dipper —
and someday he'll become a salty
Senior Master Skipper.

George Culp 1952

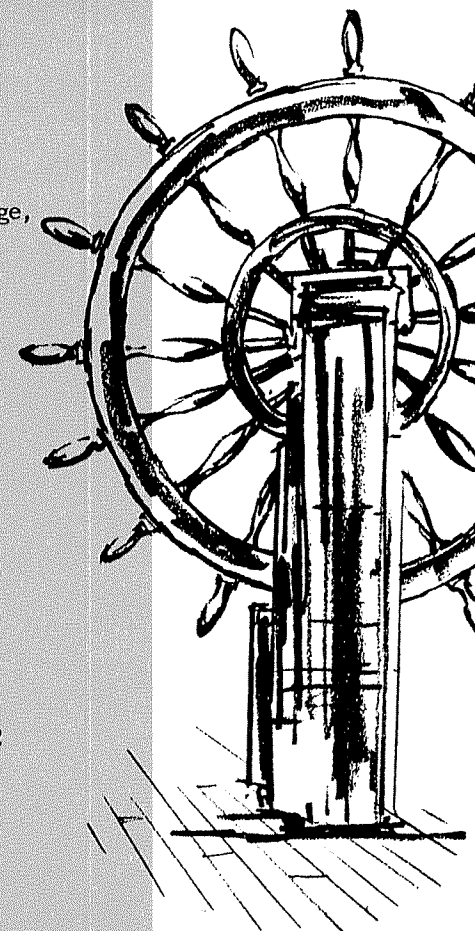

THE FOLLOWING PAGES LIST

Our Happy Subscribers

Without their financial aid neither this program nor much of the entertainment during LYRA week would be possible.

Whenever possible, please support them.

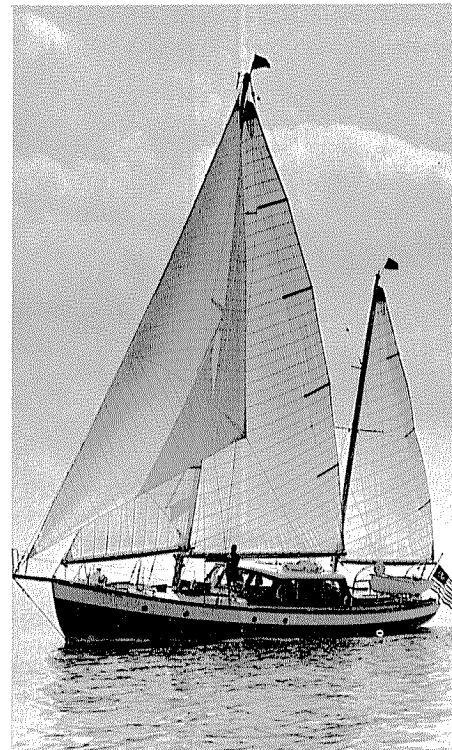

"FLYING GULL"

OWNED BY

F. Ritter Shumway

"MALLARD"

OWNED BY

Frank R. Shumway Jr.

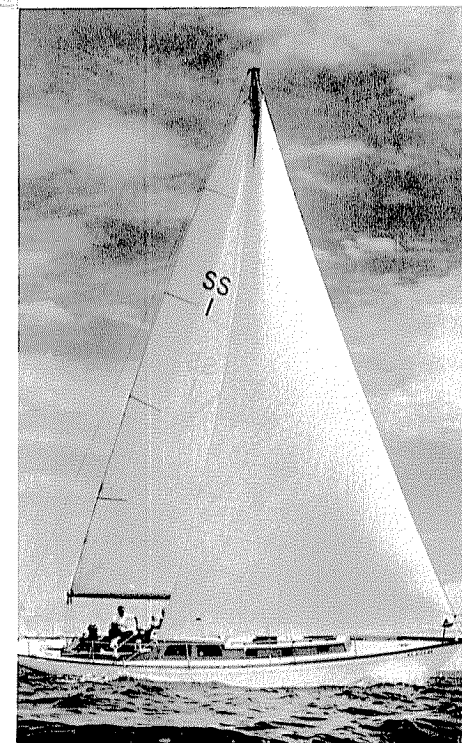

WBBF  **DIAL 95**

ONE OF AMERICA'S
MOST POPULAR
RADIO STATIONS

WBBF  **DIAL 101.3**

ROCHESTER'S
CONTINUOUS
CONCERT
STATION

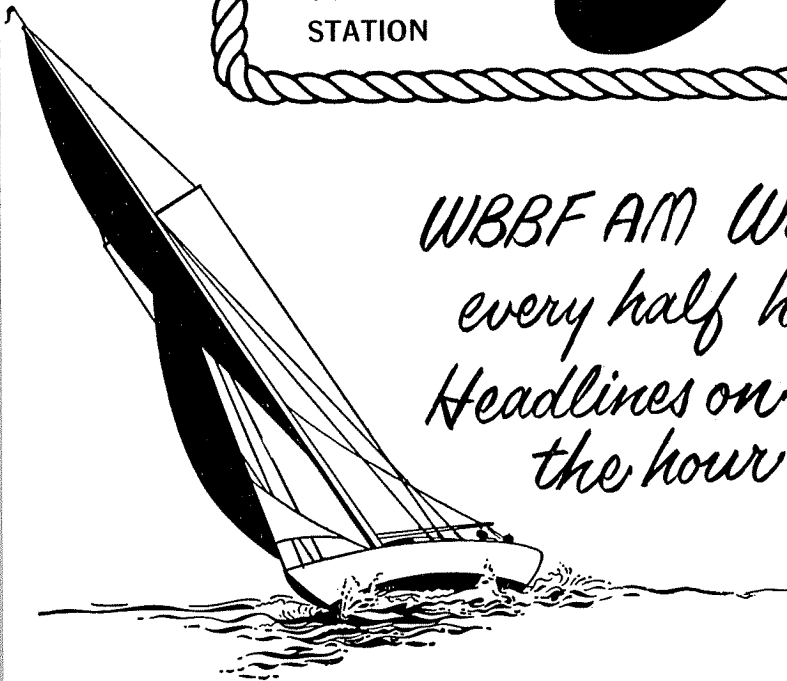

*WBBF AM Weather
every half hour....
Headlines on
the hour*

Sailing the St. Lawrence?
Tie-Up at TREADWAY'S
THOUSAND ISLANDS CLUB
A COMPLETE VACATION RESORT

Located on Wellesley Island in the St. Lawrence River, our facilities include a yacht basin, docking privileges, elegant dining, cocktail lounge and dancing, spacious guest rooms, waterfront cottages. Recreation unlimited: 18-hole PGA Golf Course • Tennis • Cycling • Fishing • Horseback Riding • Swimming Pool.

Open October 15. For reservations, color brochure and rates, phone 482-2551 or write John S. Packard, Innkeeper.



Thousand Islands Club
A Treadway Resort
Alexandria Bay, N. Y.

SILL'S MARINA

SODUS POINT

PHONE 315-483-7374

YACHT SALES • STORAGE •
DOCKAGE • REPAIRS

COMPLETE WATERFRONT SERVICE

**The Bright Spot
on Lake Avenue**

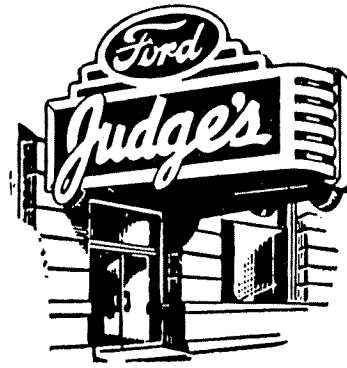

Canadian Northern Company

10 FRONT STREET SOUTH
PORT CREDIT, ONTARIO, CANADA

Cables: Canorco Tel. CRescent 8-5081

NEW AND USED YACHTS

DESIGN, CONSTRUCTION
and BROKERAGE

VALLEY ECHO CATERERS

2328 BROWNCROFT BLVD.

BU 8-7655

•••

JIM FOLEY, Manager

Eat Fresh Vegetables

They're Good for You

WEBSTER-ONTARIO FARMS



Allyn, Clements, Small, Inc.

"A COMPLETE
INSURANCE ORGANIZATION"

1237 MIDTOWN TOWER
ROCHESTER 4, NEW YORK

HA 6-6494

DAVE ALLYN

GORDON SMALL

Weatherly is insured by Chubb & Son Inc., whom we have represented since 1930, just as every America's Cup defender has been for over half a century.

Herrema's White City IGA Food Market

720 WASHINGTON AVENUE
FI 2-4240

OFFICIAL SUPPLIER
1963 LYRA AND ROCHESTER RACE

ORDERS TAKEN AND DELIVERIES MADE
AT THE INFORMATION TENT
RYC PARKING LOT

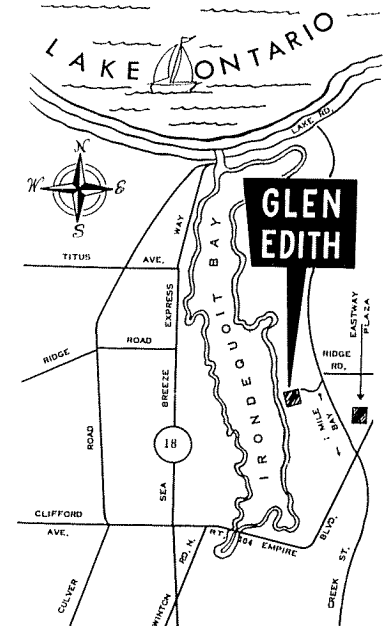

GLEN EDITH
*Where Every Meal is a
Pleasant Memory*
WEBSTER, NEW YORK

Good Luck

"Lady Linden"

L. B. B.

"Compliments

of

a

RYC Member"

"A Friend

of

Rochester

Yacht Club"

"Support

Your Olympic

Yacht Racing

Committee"

Compliments

of

WHEC

"Compliments

of

Hotai"

PATRONS

ROBERT KORTS

NEIL LEACH

JIM MATHEOS

JOE INGERSON

BERENZA IRON WORKS

JUDSON H. SCOTT

ART MOHR



ROCHESTER, N.Y.

Gentlemens Apparel
&
Ladies' Ready-Mades

COMPLETE LINE OF MEN'S & LADIES' FASHIONS

2920 MONROE AVE.

DU-1-2411

ROCHESTER, N. Y.

"The Sign of the Old Red Barn"

CONGRATULATIONS TO L. Y. R. A. & ROCHESTER YACHT CLUB

Winslow, Cogh & Stetson

INCORPORATED

INVESTMENT SECURITIES
MANGER HOTEL MEZZANINE
26 CLINTON AVE. SOUTH
ROCHESTER 4, N. Y.
TEL. LOCUST 2-4044

FREDERIC S. NUSBAUM, Resident Manager

Compliments

of a

Member

ROCHESTER STATIONERY

CO., INC.

ROCHESTER'S
LEADING
DISTRIBUTOR OF

**OFFICE
FURNITURE
OFFICE SUPPLIES
OFFICE SYSTEMS**

CONCERNED ABOUT CAPITAL OUTLAY?

LEASE AND RENTAL PLANS

SHOPPING FOR OFFICE FURNITURE?
VISIT OUR MAMMOTH **DISPLAY**
OF FURNISHINGS FOR

EVERY BUDGET. LET OUR
DESIGNERS ASSIST IN
PLANNING

AN EFFICIENT AND COLOR-
FUL OFFICE

8 JAY STREET

LOcust 2-5850



Welcome to ROCHESTER

LYRA'S Annual Regatta

The Democrat and Chronicle and The Rochester Times-Union welcome the Lake Yacht Racing Association's big sailing competition, to which Rochester Yacht Club is host for the first time since 1957.

●
Congratulations

to the Rochester Yacht Club committee members, for the excellent preparations for this major Great Lakes yachting event.

The Rochester Times-Union and The Democrat and Chronicle will give complete yachting coverage to this important LYRA REGATTA.

Follow this event and all yacht news in

The Rochester **TIMES-UNION • DEMOCRAT and CHRONICLE**



MARINE PRODUCTS

FUELS - GASOLINE & DIESEL
MOBIL OIL - INBOARD & OUTBOARD
MOBIL GREASE - ABOVE & BELOW
THE WATER
MOBIL MARINE BATTERIES
CHAMPION SPARK PLUGS

For more pleasant cruising write for your Mobil Cruising
Guide Series to:

MOBIL OIL COMPANY,
MARINE RETAIL DEPT.
150 EAST 42ND ST.
NEW YORK 17, N. Y.

Dietrich - Sibley

AGENCY INC.
GENERAL INSURANCE & BONDS
INCLUDING
COMPLETE MARINE COVERAGE
Your Inquiries Are Invited

LO 2-7550

550 EAST MAIN ST.

ROCHESTER, N. Y.

You'll enjoy

ROCHESTER

Most at the



**SHERATON
HOTEL**

111 EAST AVE.
WILLIAM P. GORMAN, Gen. Mgr.

"Seconds from Midtown"

**SPECIAL SUMMER
WEEKEND RATES!**

Thur., Fri., Sat., Sun. nights thru Sept. 15

**LARGE AIR-CONDITIONED
ROOMS! FREE PARKING!**

\$5.50
per person
per day
2 adults
to a room
Children FREE when
occupying room with parents.

THE HOLAHAN AGENCY, INC.

"Service on a Professional Level"

Insurance

WE WRITE ALL FORMS OF INSURANCE AND ARE AGENTS
FOR TWO OF THE LEADING YACHT INSURERS:
CHUBB & SON, INC., AND THE INSURANCE COMPANY OF NORTH AMERICA

42 EAST AVENUE ROCHESTER 4, NEW YORK
BA 5-0926

Yachtsmen, NOW HEAR THIS!
WROC brings you . . .

LAKE ONTARIO WEATHER FORECASTS
Every Hour on the
Half Hour

THE LATEST NEWS
Local • National •
International

MUSIC TO SAIL BY
Popular Music You'll
Enjoy

WROC RADIO
ROCHESTER, N.Y. 1280 NBC

The New WROC
Sound of the City



$\frac{8}{US20}$
"Conewago"

$\frac{R}{56}$
"Safara"

11
Si Si

$\frac{14}{US3}$
"Torew"

$\frac{6}{US55}$
"Stork"

$\frac{6}{US81}$
"Goose"

★
4222

"Snow Goose"

$\frac{8}{US15}$
"Cayuga"

$\frac{14}{US382}$
"Stork Too"

Welcome
and
Good Sailing

ROONEY CASTLE

JERRY CASTLE

COMPLIMENTS

OF

Sarah Coventry

INC.

MAKERS OF

FINE FASHION JEWELRY

NEWARK, NEW YORK STATE

PAPER and PACKAGING

.... SINCE 1907

Robfogel Mill-Andrews Corporation



47 SCRANTON ST.

ROCHESTER, N.Y.

P. O. BOX NO. 997 • AREA CODE NO. 716 • LO 2-8900



COMPLIMENTS OF

Jim

&

Bob Corbett

W. M. MORSE LUMBER CO.

340 MAIN STREET WEST

ROCHESTER, NEW YORK

FA 8-1400

•
NORTH END BRANCH

THOMAS AVENUE

IRONDEQUOIT

**A. FRIEDERICH
&
SONS CO.**

BEST WISHES FROM
THE RYC
STAR FLEET

**Compliments
of
“Sam”**

THE MOST COMPLETE
TRAVEL & VACATION
SERVICE
IN THE STATE



**Grinnell's
KALBFLEISCH
Travel Agency**

233 MIDTOWN PLAZA
On The Terrace
BAker 5-5440

Newell Grinnell, Pres. Member A.S.T.A.

COMPLIMENTS OF

**CHAMPION
KNITWEAR CO., INC.**

115 COLLEGE AVENUE
ROCHESTER 7, NEW YORK

SPARKMAN & STEPHENS
INCORPORATED
11 EAST 44TH ST., NEW YORK



**Naval Architects—Yacht Brokers
Marine Insurance**

DESIGNERS OF
ONAIRE III MADAME MALLARD
FLYING GULL FAIRWIND
ZEST VAYU LADY LINDEN SI SI

Good Luck!

Len and Bob Anderson

Howard Rekers, Inc.

20 VAN VOORHRS AVENUE

FI 2-1503

ENGINEERING SERVICES

"NORDIC STAR"

REMEMBER

THE

ALAMO!

HEDGES

NINE MILE POINT HOTEL

for the finest cuisine on the lake

FROM PORT OF ROCHESTER:

Bearing – 090° True

Distance – 8-1/3 miles

Depth of Harbor – 6'

Dock Space and Conditions –
Excellent

We Welcome Yachtsmen at All Times

STAN NOROKI, Proprietor

Marine Supplies

MOST COMPLETE LINE IN UPSTATE NEW YORK

POWER • SAIL

CHARTS, PAINT, HARDWARE, CANVAS, ROPE, INSTRUMENTS, RADIO,
GEAR, NAVIGATION GEAR, CUSHIONS, PRESERVES, WATER FENDERS, ETC.

1333 ST. PAUL STREET

MAYER BOAT

CO 6-6857

**MATTHEWS & FIELDS
LUMBER CO., INC.**

RELIABILITY FOR 66 YEARS

PLYWOOD ● INTERIOR TRIM
ROOF TRUSSES ● ANDERSON & MALTA
WINDOWS ● HARDWARE ● LUMBER
ROOFING ● INSULATION

2 CONVENIENT LOCATIONS

NORTH SIDE
NO 3-0430
120 STONEWOOD AVE.

SOUTH SIDE
ED 4-5500
1230 LEHIGH STA. RD.

Dolomite

Products

Company

METRO MARINE

BRONTE, ONTARIO

MARINE REPAIRS AND SERVICE

JOHN WALKER, Proprietor

Compliments

of

**HEIL
GRINDING CO.**

447 ADIRONDACK STREET

GL 8-3927

Ebert's Liquor Store

LICENSE NO. L4243

751 WASHINGTON AVE.

FI 2-5988

Official Purveyors of Spirits to the LYRA Regatta

DELIVERIES DIRECTLY FROM OUR SHELF
TO YOUR GALLEY

BEST WISHES TO LYRA

**GMW Offset
Service Inc.**

35 SOUTH AVENUE

HA 6-1029

GOOD LUCK TO LYRA

**Jolly Boat
Fleet No. 7**

R. Y. C.

Policy of the Month

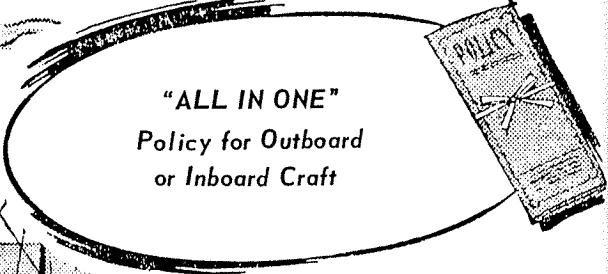
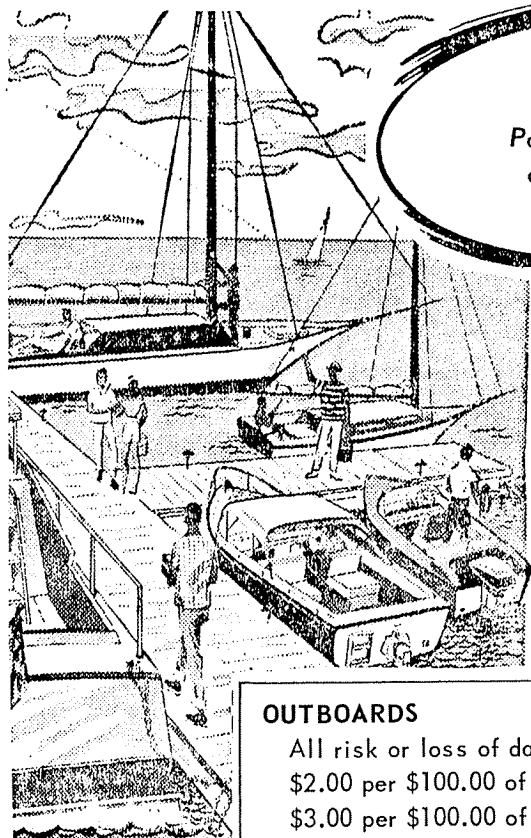

"ALL IN ONE"
Policy for Outboard
or Inboard Craft

RATES

Tailored To Your
Craft and Needs

SAFE BOATING

Can Lower Your
Rate Even More

OUTBOARDS

All risk or loss of damage
\$2.00 per \$100.00 of Boats value w/\$25.00 deductible
\$3.00 per \$100.00 of Boats value w/no deductible
Plus 15% Safe Boating discount on renewal after first
year with no losses.

INBOARDS and YACHTS

Rates specifically tailored to your Craft
Plus 15% Safe Boating discount on renewal after first
year with no losses.

*Phone or Drop In Today For
FREE Quotations on Your Needs
and pick up your Free "Key Float"*

EGBERT F. ASHLEY CO.

300 FIRST FEDERAL SAVINGS BUILDING
328 MAIN STREET EAST
ROCHESTER 4, NEW YORK
Phone: HAmilton 6-1858
ASH AND VINCE PALMER

JAMES JOHNSTON AGENCY, INC,

1020 SIBLEY TOWER BUILDING

...

INSURANCE

...

HA 6-9930

PHIL GOODWIN

VINCE PRICE

TO A

GRAND OLD SAILOR

Eric "Pete" Moore

BUD CLANCY

We Suit the Great Minority



Robert F. Ryan Ltd.

Midtown Plaza

NATURAL COLOR LITHOGRAPHY FOR PRINTED ADVERTISING
DESIGN • ART • PHOTOGRAPHY • PLANNING • PRODUCTION

GENERAL COLOR PRINTING, INC.

936 EXCHANGE STREET
ROCHESTER 8, NEW YORK

FAirview 8-4674

THOROUGHBRED RACING

MAY 28 – SEPTEMBER 21

FINGER LAKES RACE TRACK

CANANDAIGUA, NEW YORK
THRUWAY EXIT 44

POST TIME 2.00 P.M.

GENERAL ADMISSION \$1.50

RACING EVERYDAY
(Except Sundays)

Leo J. Roth Corp.

SHEET METAL WORK

HEATING — ROOFING

214 CLIFFORD AVENUE ROCHESTER 21, NEW YORK

FI 2-1740



Blue Boy

DAIRY Inc.

ICE CREAM COMPANY

BO'SON MARINE SALES, Inc.

40 FRANKLIN STREET

ROCHESTER, NEW YORK

HA 6-4662

authorized dealer for MATTHEWS CRUISERS

affiliated with

TRIANGLE MARINE, INC. of Rochester, New York

and

HUTCHINSON'S BOAT WORKS of Alexandria Bay, New York

MAKE THE POWERS HOTEL YOUR HEADQUARTERS IN ROCHESTER, NEW YORK

- 300 Large, Comfortable Sleeping Rooms with TV
Family plan – no charge for children under 14 years
of age when accompanied by parents
Free 24 Hour Parking for overnight guests
- 3 Air Conditioned Restaurants
Cafe D'Or and Tap Room – Air Conditioned
Wedgewood Main Dining Room – Air Conditioned
Coffee Shop – Air Conditioned
Finest Quality Food
- Central Location at West Main and Fitzhugh Streets
- Banquet and Meeting Facilities all air conditioned

THE POWERS HOTEL

WEST MAIN AND FITZHUGH STREETS

ROCHESTER 14, NEW YORK

Rochester's

Leading Chevrolet

Dealer

HEINRICH MOTORS

214 LAKE AVENUE

"Where Every Deal Means

A Great Deal"



***People in the know,
people on the go,
enjoy the Genesecret!***

(it's lightness with flavor!)



© 1962 The Genesee Brewing Co., Inc., Rochester, N. Y.

HEINRICH MARINE INC.

409 RIDGE ROAD UN 5-3600

*New and Used Boats,
Motors, and Trailers*

EVINRUDE — PENN YAN — ALUMA CRAFT —

ALPEX TRAILERS — MARINE SUPPLIES



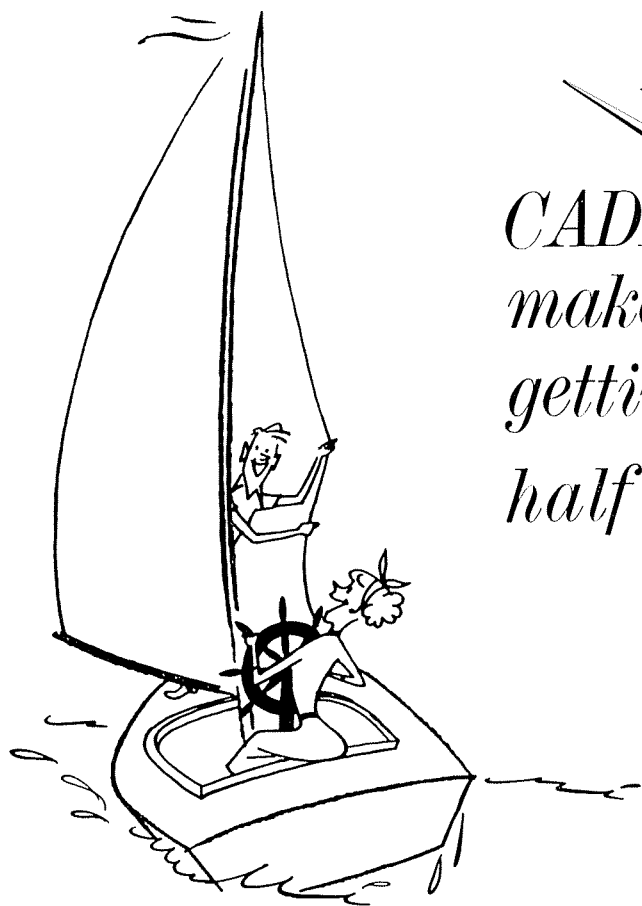

*CADILLAC
makes
getting there
half the fun!*

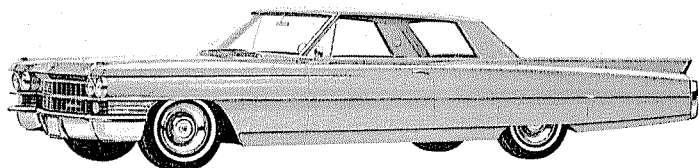

Private showing at your home by appointment

THE VALLEY CADILLAC CORP.

333 EAST AVENUE, ROCHESTER 4, NEW YORK, BA 5-3440

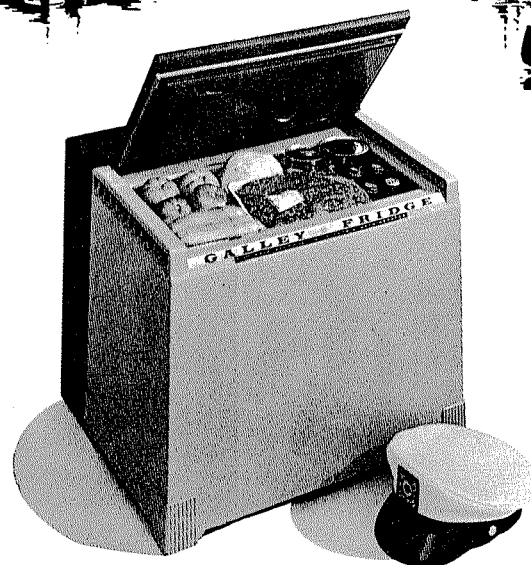

***NOW! A sensational marine refrigerator that
operates on either alcohol, 12 volt or 110 volt electric!***

Ideal for mariners and all-sized boats

■ For the first time, a *real* refrigerator for boats! ■ Safe, automatic, and dependable, the Galley Fridge runs on low-cost disposable alcohol cylinders, sold by boatyards, marinas and yacht chandlers everywhere. It employs a revolutionary new safety principle which renders it completely explosion-proof. ■ Self-contained and portable . . . use it anywhere. ■ Electric operation doesn't run down your boat's batteries. ■ No filling—no spilling—no pumping—no priming, connect replacement cylinder, throw away the empty. ■ So reliable, it comes with a *Five-Year Guarantee*. ■ Operates on the same principle as many home refrigerators, but has *no* moving parts, and is completely silent in operation.

GF-A/12/110 Combination model operating on either alcohol, 12 volt or 110 volt electric power \$159.95

produced and manufactured by

BERNZOMATIC CORPORATION ROCHESTER, NEW YORK

The wonderful fuel supply that makes the Galley Fridge possible comes in safe, disposable aluminum cylinders. Just \$1.95 each or a six-pak only \$11.00 even.



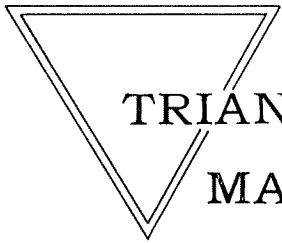

**TRIANGLE
MARINE, INC.**

5395 ST. PAUL BOULEVARD
ROCHESTER 17, NEW YORK
Fillmore 2-0220 • Area Code 716



Welcome Sailors!

We hope you will visit us during the regatta – right next door to the Rochester Yacht Club. For your convenience our showrooms will be open from 9:00 AM to 9:00 PM, August 5th – 10th. We will also endeavour to operate on a “stand-by” basis to assist you with any emergency repairs that might be necessary.

We specialize in Sailboats and Sailboat Supplies. We stock MERRIMAN, RACE-LITE, SEABOARD hardware, INTERNATIONAL Paints, K-TING line, SAMSON braid, PVC foul weather gear, TOP-SIDERS and many other items too numerous to list.

Triangle Marine is run by Sailors for Sailors. Come aboard! Good Luck!

Charles E. Angle
President

E. Clinton Wolcott
Vice-President and Treasurer

DOUGLAS BLUE JR.
REALTOR

EDWARD R. COWLES

DOUGLAS BLUE JR.

- Residential properties
- Farms and Country Estates
 - Vacant Land and Building Lots
 - Commercial Sales and Investments
 - Mortgages

Member Rochester Real Estate Board

20 SIBLEY PLACE
ROCHESTER 7, NEW YORK

TELEPHONE
CH 4-1452



**rooms
aweigh**

Be our guests. We've got very, very plush accommodations right on top of Rochester's famous Midtown Plaza Tower. The food and service? Best you'll find west of Skaneateles. And the view from any room will take your breath away. Indulge yourselves. Better yet —let us do it.

For reservations, call BAKER 5-9000

Midtown Tower Hotel

HOME OF THE FAMOUS TOP OF THE PLAZA RESTAURANT
ATOP ROCHESTER'S MIDTOWN TOWER

Bill Kallusch Boats

SODUS POINT, NEW YORK

Since 1924

- Custom building
- Complete marine repair facilities
- Inside and outside storage
- Builders of the Rhodes Bantam[®]
- Marine Railway to 20 tons
- Mobile hoist to 10 tons
- Spar hoist

OPEN YEAR AROUND

When you stay at the DOWNTOWNER...

... you return at the end of the day's activities to a refreshing dip in the pool (the only motel pool in the heart of Rochester).

You live in quiet, air-conditioned luxury at the Downtowner, just a block from Midtown Plaza and other leading stores and shops. 240 modern rooms (single, from \$9.85) have direct dial phones, oversized double beds, TV and hi-fi. Free underground parking by attendants. Ice machines on every floor.

We look forward to welcoming you. For reservations, call LO 2-5480 in Rochester, New York, or TWX 716-235-1249.

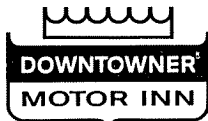
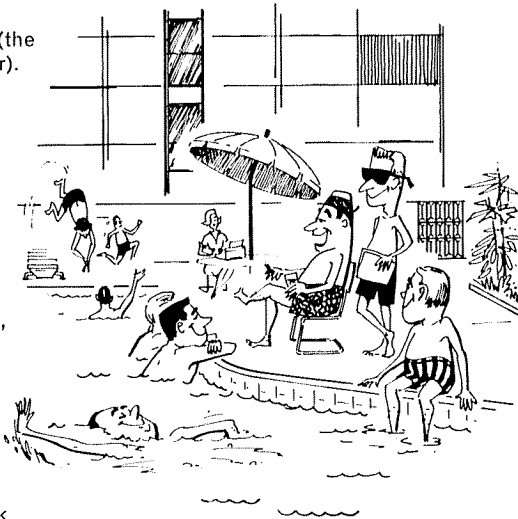

BROAD AND SOUTH AVE., ROCHESTER 4, NEW YORK

COMPLIMENTS OF

Gurstner & Statt

TILE AND MARBLE CONTRACTORS

48 MOUNT HOPE AVENUE

ROCHESTER, NEW YORK

"NO THANKS"

make it a highball
... and make it
with Canada Dry

Canada Dry Mixers make highballs taste brighter, stay livelier longer. Help you wake next morning with no unpleasant aftereffects. Reason: Canada Dry's exclusive "Pin-Point Carbonation." Make your next drink a highball—and make the mixer Canada Dry.

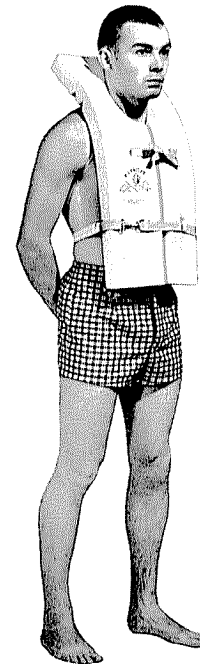

for the finest

wear

FLOATEX®

- LIFE VESTS
 - SKI-SAFES
 - SWIM VESTS
- ALL VINYL FOAM -- VINYL COATED

In Rochester - Sibley's
- Monroe Toy Shops
and at leading marine dealers

PROTECTION EQUIPMENT CO.

100 FERNWOOD AVE. ROCHESTER 21, N.Y.

Let's Keep

This A Good

Clean Regatta

WE'LL HELP BY PICKING UP YOUR LAUNDRY
AND DRYCLEANING AT THE INFORMATION BOOTH
EVERY DAY AT 2 P.M.



CRESCENT PURITAN

LAUNDERING • DRY CLEANING • FUR STORAGE
1630 DEWEY AVENUE • ROCHESTER 15, NEW YORK • CLEARWATER 4-4000

Compliments
of
Boller Clark Agency, Inc.

A DIVISION OF
MARSH & McLENNAN
INCORPORATED
Insurance Brokers

21 MAIN STREET, East ROCHESTER 4, NEW YORK

LOG

LOG

"An honest brew makes its own friends"

John Molson, Montreal, 1786



Maybe this is the reason Molson is the largest selling ale in Canada today. And now, Molson Ale and Canadian Lager Beer are being specially imported for sale in clubs, taverns, and stores in and around the area



MOLSON OF CANADA

Distributed by: WRIGHT-WISNER DISTRIBUTING CO., Rochester, N.Y.